

FC420 Bridge Option User's Guide

Introduction	3
Fibre Channel Overview	3
Library Operation after FC420 Bridge Installation.....	4
Cabling the Library for Fibre Channel	4
One- and Two-Drive Library Cabling.....	4
Cabling an L100 with Three or More Drives	6
Setting SCSI IDs	9
FC420 Services Software Commands	10
FC420 Service Software Operation	10
Command Syntax.....	10
List of Abbreviations.....	11
Command Listing.....	11
FC420 Blink Codes	22
Configuring FC420 Firmware	25
Setting Up an Ethernet Connection	26
Verifying Current FC420 Firmware.....	28

Scanning the SCSI Busses on the Library	28
Creating a Map File for the FC420.....	29
Making Other Configuration Changes	29
Restoring the PC to Its Original Configuration.....	30

Introduction

This document explains how to configure and operate the FC420 Fibre Channel Bridge option installed in a Sun StorEdge™ L25 tape library or a Sun StorEdge™ L100 tape library.

Note: Hereafter in this document, the Sun StorEdge L25 and Sun StorEdge L100 tape libraries will be referred to as the L25 and the L100.

For FC420 installation steps, refer to the *FC420 Fibre Channel Bridge Quick Reference Guide* (PN 6423041).

For a description of L25 and L100 operating procedures, refer to the *Sun StorEdge™ L25 Tape Library and Sun StorEdge™ L100 Tape Library User's Guide* (PN 6423016).

Note: If you do not have an MC300 Prism Management Card (PMC), refer to [Configuring FC420 Firmware](#) on page 25 to configure and troubleshoot your FC420 bridge (or bridges).

Fibre Channel Overview

The L25 and L100 are controlled by a host computer via an LVD SCSI differential bus using the SCSI-2 medium changer command set. The architecture of the libraries allows for easy conversion from the SCSI host interface to a Fibre Channel host interface by installing the FC420 bridge option.

Fibre Channel is a serial data transfer architecture for use with computers and mass storage devices. Fibre Channel is rapidly emerging to challenge SCSI as the interface of choice for host-to-storage applications.

Fibre Channel advantages include:

- Connection distances of up to 10 Kilometers
- Up to 2 Gb transfer rates via Auto-negotiate (alternatively, Auto-negotiated transfers rates up to 2 Gb)
- Support for up to 126 devices on a loop
- Support for x24-bit addressing for over 16 million devices in point-to-point (PTP) mode or fabric, when using a Fibre Channel switch or multiple Fibre Channel switches
- Operating system independence
- Interconnect flexibility

- Fibre Channel fabric switches provide full direct connectivity between all ports on a storage area network (SAN), which can increase the total throughput of all devices on the SAN

Library Operation after FC420 Bridge Installation

Once the FC420 Bridge SCSI to Fibre Channel option is installed and tested, the library operates exactly as a library with a SCSI host interface. User operation of the library via the graphical user interface (GUI) panel is unchanged.

Cabling the Library for Fibre Channel

The cabling configuration used for the L25 and L100 with the FC420 bridge option depends on the following factors:

- Number of tape drives installed
- Tape drive type (SDLT 320, HP LTO Gen 1, or HP LTO Gen 2)
- Number of FC420 bridges installed
- Data transfer rate of the storage area network (SAN)

One- and Two-Drive Library Cabling

If you are cabling an L25 library, or an L100 library with only one or two tape drives, the cabling is the same regardless of drive type or SAN. One- or two-drive libraries require only one FC420 bridge.

[Figure 1](#) shows the cabling for a one-drive library.

Figure 1 One-Drive Library Cabling

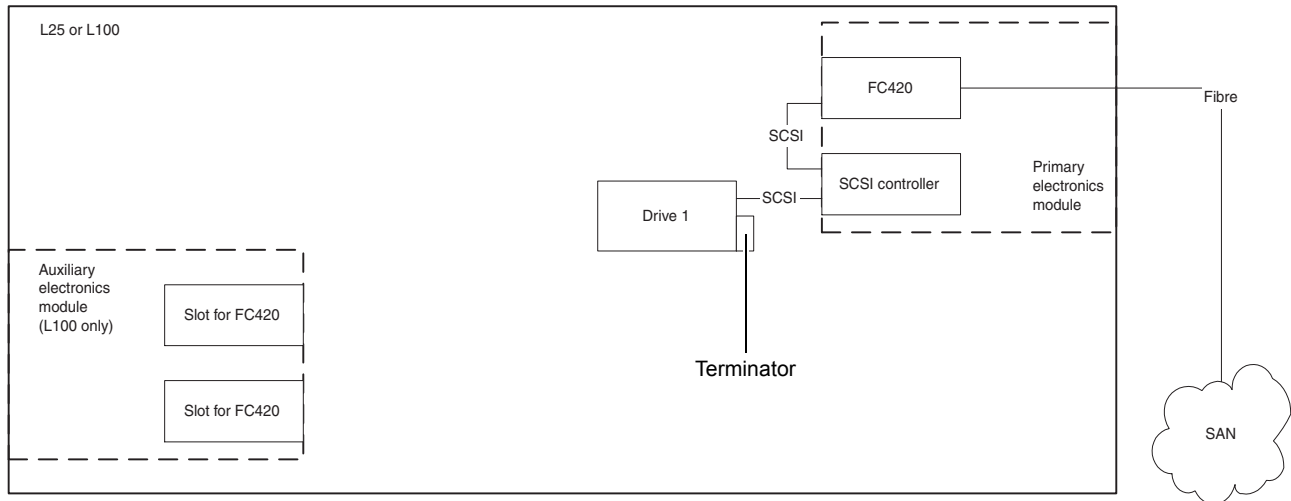

In a one-drive configuration (see [figure 1](#)), a SCSI daisy chain is established from one of the SCSI ports on the FC420 bridge to the robotics SCSI controller and then to drive 1, where the daisy chain is terminated. The robotics SCSI controller is included in the chain to pass SCSI commands to the robot.

The robotics SCSI controller and drive 1 must be on the same SCSI bus because the robotics SCSI controller has termination disabled.

[Figure 2](#) shows typical cabling for a two-drive library.

Figure 2 Two-Drive Library Cabling

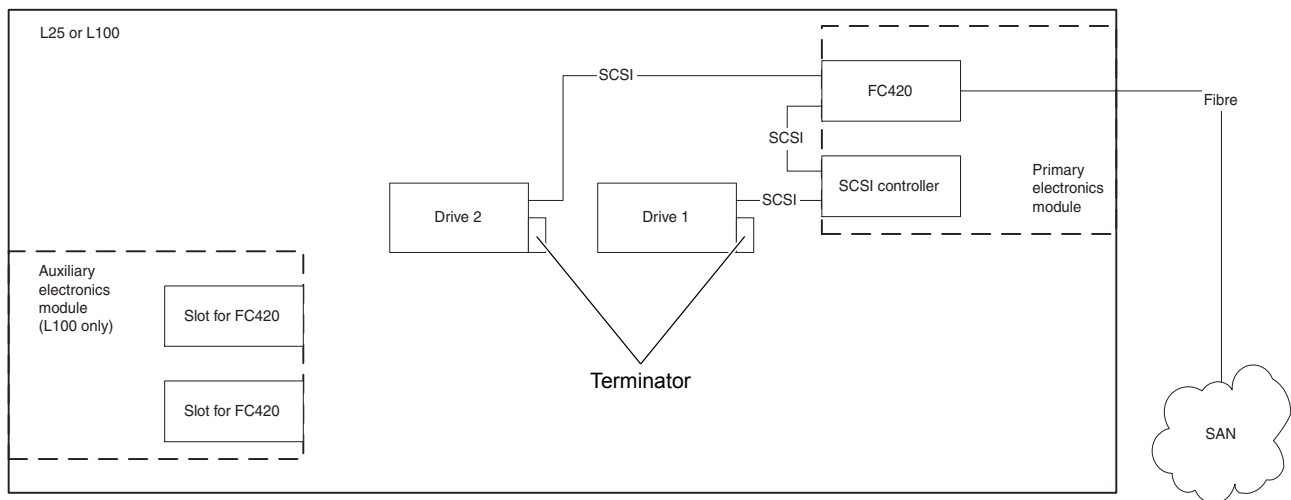

In a two-drive library, the second drive (drive 2) should be connected to the available FC420 port, creating a second SCSI bus. This utilizes the FC420 bridge fully and maximizes the communication bandwidth available to each tape drive.

Cabling an L100 with Three or More Drives

When cabling an L100 with three or more tape drives, you need to know the type of tape drive installed in the library and the data transfer rate of the SAN to determine the correct SCSI configuration.

Note: As with one- and two-drive configurations, all Fibre-to-SCSI cabling configurations must include the robotics SCSI controller so that SCSI commands intended for the robot are communicated successfully.

To cable a library with:

- SDLT 320 or HP LTO Gen 1 drives, refer to [SDLT 320 or HP LTO Gen 1 Drive Cabling with a 1 Gb SAN](#) or [SDLT 320 or HP LTO Gen 1 Drive Cabling with a 2 Gb SAN](#)
- HP LTO Gen 2 drives, see [HP LTO Gen 2 Cabling](#)

SDLT 320 or HP LTO Gen 1 Drive Cabling with a 1 Gb SAN

If an L100 containing SDLT 320 or HP LTO Gen 1 drives is connected to a 1 Gb SAN, a ratio of one tape drive per FC420 SCSI port is recommended. This means that three- and four-drive libraries require a second FC420 bridge, and five- and six-drive libraries require three FC420 bridges (see [figure 3](#)).

Note: SDLT and LTO tape drives are sometimes referred to as *Superdrives*.

Figure 3 One-Drive-per-FC420-Port Cabling

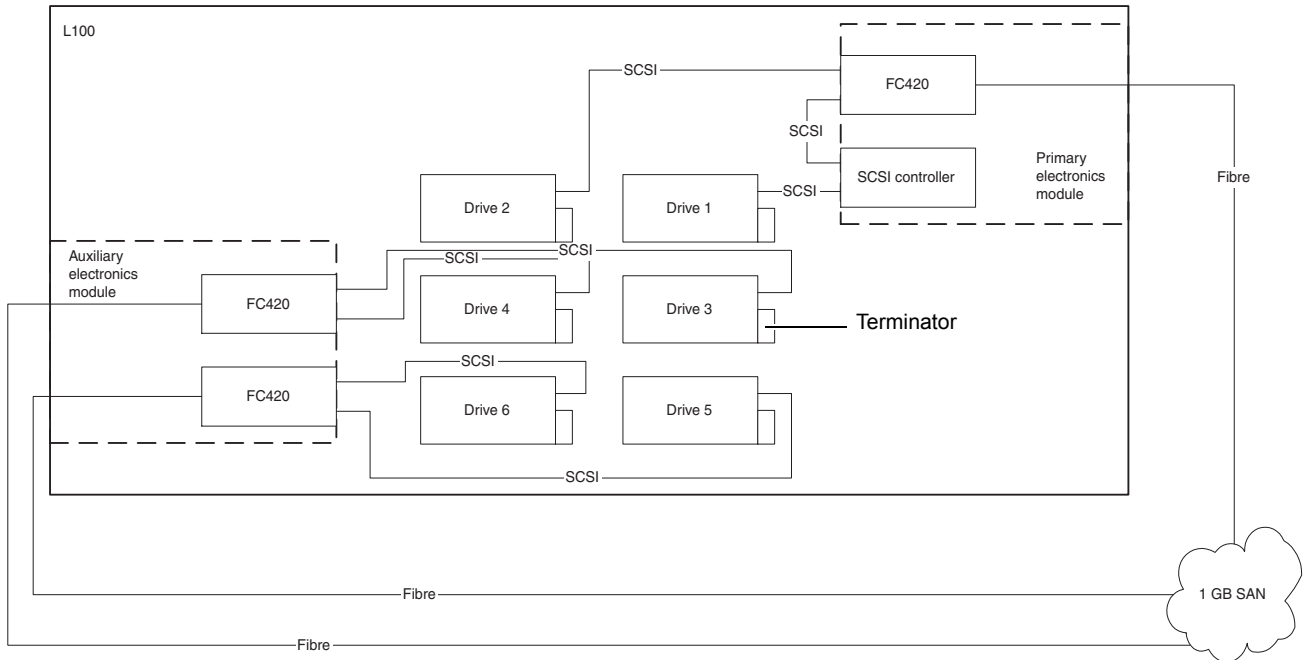

SDLT 320 or HP LTO Gen 1 Drive Cabling with a 2 Gb SAN

If an L100 containing SDLT 320 or HP LTO Gen 1 drives is connected to a 2 Gb SAN, a maximum ratio of two drives per FC420 SCSI port is recommended. This means that one FC420 bridge can manage up to four tape drives, but a second FC420 bridge is required for libraries with five or six tape drives.

[Figure 4](#) shows a six-drive library utilizing a two-drive per SCSI port cabling scheme.

Note: To increase the bandwidth available to each tape drive, install additional FC420 bridges (see [figure 3](#)).

Figure 4 Two-Drive-per-FC420-Port Cabling

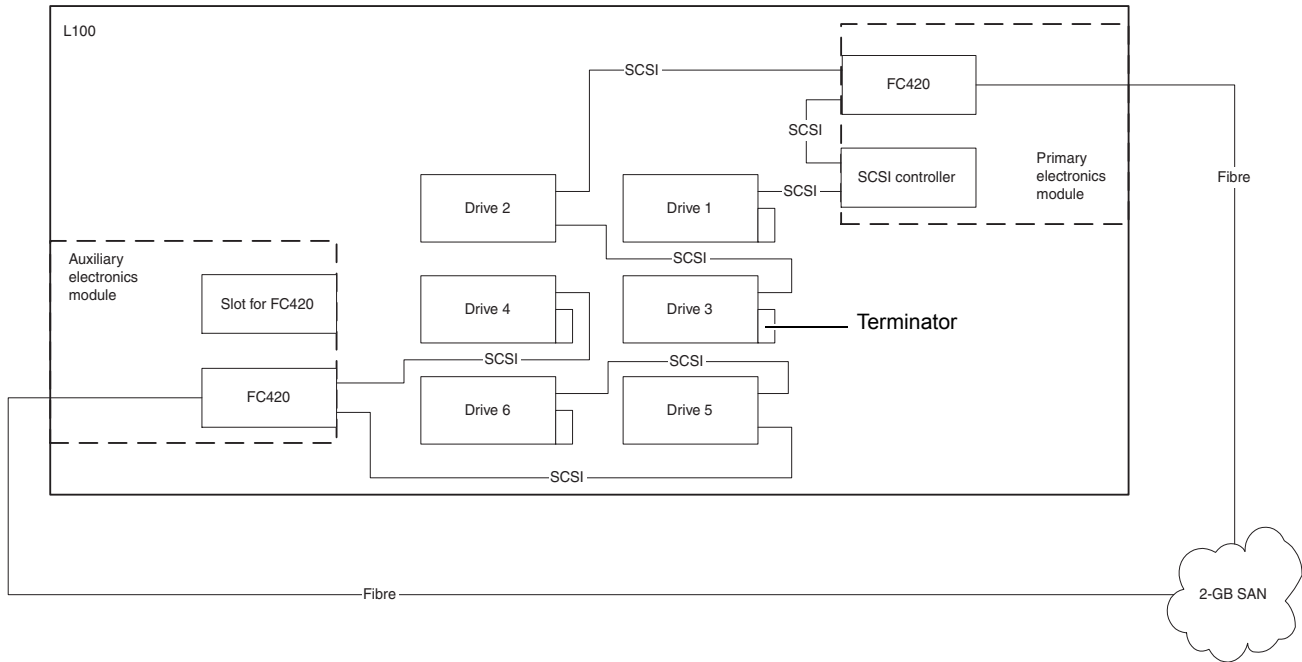

HP LTO Gen 2 Cabling

HP LTO Gen 2 drives can only be used with a 2 Gb SAN. A ratio of one tape drive per FC420 SCSI port is recommended. This means that three- and four-drive libraries require a second FC420 bridge, and five- and six-drive libraries require three FC420 bridges (see [figure 5](#)).

Figure 5 HP LTO Gen 2
 Drive Cabling

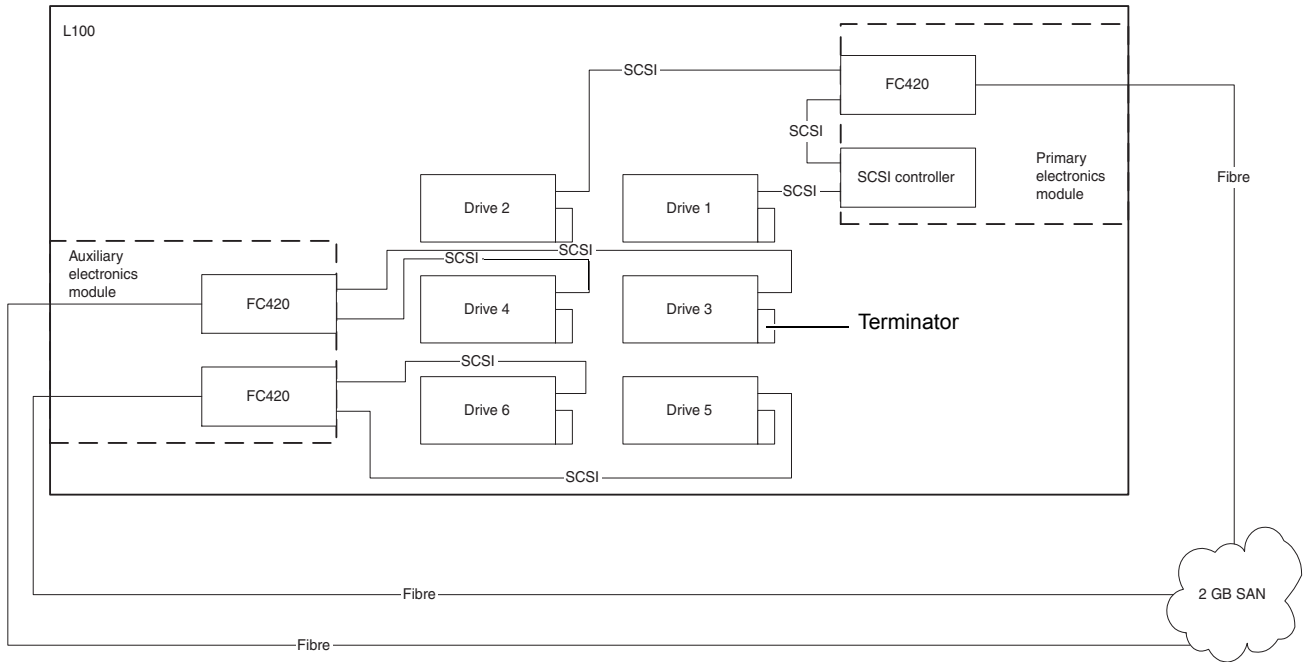

Setting SCSI IDs

Set the SCSI device addressing (SCSI IDs) for the library (see [table 1](#)).

Table 1 SCSI ID Settings

Device	SCSI ID	Device	SCSI ID
Robotics SCSI controller	0	Drive 4	4
Drive 1	1	Drive 5	5
Drive 2	2	Drive 6	6
Drive 3	3		

FC420 Services Software Commands

The FC420 Services Software is resident on each FC420 Bridge board, and is used to configure the bridge for use in the library. The software uses a Command Line Interface (CLI).

FC420 Service Software Operation

The Command Line Interface provides access to the FC420 services through a set of ASCII-based command lines. Commands have four types of operation:

- *Immediate* – cause an immediate action; not preceded by a **get** or **set** operation.
- *Get* – returns the current value of a parameter or setting. This command may be abbreviated to “g.”
- *Set* – changes the value of a parameter or setting. This command may be abbreviated “s,” and does not take effect until a `SaveConfiguration` command is sent.
- *Usage* – if the form of an operation cannot be determined, it is assumed to be the “Usage” form and a brief help message is displayed.

The commands are not case sensitive.

Decimal numbers may be entered as raw numerical input, such as 123.

Octal numbers must be preceded by the number 0, for example 0713.

Hexadecimal numbers must be preceded by the C-style of 0x prefix, such as 0x1FA4.

Quoted strings are treated as a single parameter for any command which expects character input, regardless of space in the string.

Several non-immediate commands require a `SaveConfiguration` before their modified parameters take effect. When such a command is executed an asterisk appears next to the command line prompt.

Command Syntax

The following is a list of syntax used to describe command lines:

- [] indicates required entry
- < > indicates optional entry
- | indicates choose one entry

List of Abbreviations

The following is a list of abbreviations used to describe command lines:

- fp Fibre Channel port number (0)
- fl Fibre Channel LUN (0 - 31)
- sb SCSI bus number (0 - 1)
- st SCSI target ID (1 - 15)
- sl SCSI LUN (0 - 7)

Command Listing

[Table 2](#) lists the currently available FC420 Services Software commands.

Table 2 FC420 Services Commands

Command	Description	Default	Syntax
AutoMap (Immediate)	Automatically maps all currently operational SCSI devices attached to the FC420 bridge. Issue an FCPortList and a SCSIPortList command before issuing an AutoMap command because AutoMap ignores devices attached to a non-operational SCSI bus and assigns devices to a non-operational Fibre Channel port.		automap automap [fp]
BootFibreDelay	Selects/displays the boot fibre delay (in seconds)	0	set bootfibredelay [0 15 30] get bootfibredelay
BootScan	Enables/disables the boot scan feature. This feature provides dynamic mapping of SCSI devices to fibre port/LUN combinations via a SCSI port at boot time.	enabled	set bootscan [enabled disabled] get bootscan
BootScanPorts	Selects/displays the ports to be used for a boot scan.	all	set bootscanports [fp all auto] get bootscanports
ClearEvent (Immediate)	Clears the contents of the event log.		clearevent
DhcpFixedDelay	Selects/displays the delay interval (in seconds) between DHCP client requests.	5	set dhcpfixeddelay [0...255] get dhcpfixeddelay

Command	Description	Default	Syntax
<p>DispEvent</p> <p>Sets the switches that control the filtering performed when displaying events.</p> <p>Switches have the following settings:</p> <p>[subsystem] switch: mask that controls which subsystem events are displayed. The mask is a byte value with the following bit patterns corresponding to the currently supported subsystems:</p> <p>0x01 FCP Processor/i960 Interaction 0x02 SCSI Processor/i960 Interaction 0x04 Ethernet (Future) 0x08 Extended copy 0x20 NVRAM & Flash 0x40 ECC & Parity 0x80 Performance</p> <p>To display events from several different subsystems, use a mask value equal to the logical OR of the corresponding subsystem values. To display events from all subsystems enter the value 0x7F for the mask.</p> <p>[event_level] switch: mask that controls what reporting level events are displayed. The mask is a byte value with the following bit patterns corresponding to the currently supported reporting levels:</p> <p>0x01 Info; general information 0x02 Warning; unexpected situation/condition 0x04 Critical; operation limited/curtailed 0x08 Failure; hard failure 0x10 Other; otherwise not categorized 0x20 Debug; tracking events</p> <p>To display events from several different reporting levels, use a mask value equal to the logical OR of the corresponding reporting levels. To display events for all reporting levels enter the value 0x7F for the mask.</p> <p>[status] switch: This switch has the following two values which correspond to the status of the events to be displayed:</p> <p>all All events, regardless of their status values are displayed. ngood Only events with a status other than good are displayed.</p>	<p>0x00</p> <p>0x00</p> <p>ngood</p>	<p>0x00</p> <p>0x00</p> <p>ngood</p>	<p>set dispevent [subsystem] [event_level] [status] get dispevent</p>
<p>DispFcPortDB (Immediate)</p>	<p>Displays the contents of the specified Fibre port's internal database.</p>		<p>dispfportdb <fp></p>

Command	Description	Default	Syntax
DisplayEvent (Immediate)	Displays the current contents of the event log. The log is filtered by the current switch settings as described in the DisplayEvent section. If the optional all is selected, the display filtering is temporarily suspended and all logged events are displayed.		displayevent <all>
EccLog	Resets/displays the ECC error statistics for the FC420 bridge. The get command displays the statistics; the set command resets the statistic counters to zero.		set ecclog clear get ecclog
ErrorLog	Resets/displays the error logs for the FC420 bridge. The get command displays the logs; the set command resets the logs to zero.		set errorlog clear get errorlog
EthernetSpeed	Sets/displays the Ethernet speed of the Fibre connection. If auto is selected, the current speed of the connection is indicated in parentheses in the response to the get ethernetspeed command.	auto	set ethernetspeed [10 100 auto] get ethernetspeed
Exit (Immediate)	Exits the current Telnet command line interface (CLI) session). This command has no effect during a serial or in-band CLI session.		exit
FcAck0	Specifies whether ACK0 or ACK1 will be returned in response to a Class 2 Fibre Channel data frame or sequence. When enabled, this option sends ACK0; when disabled, this options sends ACK1.	disabled	set fcack0 [enabled disabled] get fcack0
FcClass2	Specifies whether the FC420 bridge will support Fibre Channel Class 2 (Multiplexed) or Class 3 service.	disabled	set fcclass2 [enabled disabled] get fcclass2
FcConnMode	Sets/displays the connection mode for the FC420 to arbitrated loop or PTP. This option determines the Fibre Channel port type for the FibreBridge fibre port(s). Loop mode configures the adapters for FC-AL operation, PTP mode configures the adapters as N_Ports, and loop-PTP and PTP-loop modes allows auto-negotiation.	ptp-loop	set fconnmode [loop ptp] [set get] FcConnMode [loop ptp loop- ptp ptp-loop]

Command	Description	Default	Syntax
FcDataRate	Sets/displays the data rate (in Gb/s) at which the FC420 bridge will operate.	auto	set fcdataRate [1gb 2gb auto] get fcdataRate
FcFairArb	Turns on or off the FC-AL arbitration fairness. Applies to all three Fibre Channel ports on each board.	enabled	set fcfairarb [enabled disabled] get fcfairarb
FcFullDuplex	Enables/disables full duplex communication between the FC420 bridge and other Fibre Channel devices.	enabled	set fcfullduplex [enabled disabled] get fcfullduplex
FcHard	Enables/disables Fibre Channel hard address assignment. Under soft addressing the FC420 loop address is assigned during loop initialization.	disabled	set fchard [enabled disabled] get fchard
FcHardAddress	Sets/displays the value used as the FC-AL hard address.	FC port 0 0x03	set fchardaddress [fp [address]] get fchardaddress [fp]
FcInitiator	Enables/disables the initiator function of the FC420 bridge on the Fibre channel network.	disabled	set fcinitiator [enabled disabled] get fcinitiator
FcPortList (Immediate)	Lists the available Fibre Channel ports and their current status.		fcportlist
Fcp2	Enables/disables the FC420 bridge's compliance with the FCP-2 Fibre Channel specification.	enabled	set fcp2 [enabled disabled] get fcp2
Fcp2Conf	Enables/disables the FC420 bridge's capability to request FCP_CONF IUs. This option is valid only when the fcp2 command is also enabled.	enabled	set fcp2conf [enabled disabled] get fcp2conf
Fcp2CRN	Enables/disables the FC420 bridge's capability to accept CRNs for precise delivery of SCSI commands. This option is only valid when the fcp2 command is also enabled.	disabled	set fcp2crn [enabled disabled] get fcp2crn
FcSCSIBusyStatus	Specify the SCSI status value returned when the FC420 is unable to accept a SCSI command due to a temporary lack of internal resources.	BUSY	set fcscsibusystatus [busy qfull] getfcscsibusystatus

Command	Description	Default	Syntax
FcTargets (Immediate)	Provides the node name, Fibre LUN, and inquiry data for every Fibre Channel target device visible to an FC420 bridge operating in initiator mode.		fctargets <fp>
FibreBridgeModel	Reports the specific FC420 model information.		get fibrebridgemodel
FibreBridgeName	Specify the 8-character name assigned to the FC420 bridge.		set fibrebridgename [value] get fibrebridgename
FibreBridgeTargetLUN	Specify the soft target LUN used by the FC420 when addressed by the host. This LUN is taken from NVRAM.	disabled	set fibrebridgetargetlun [0 - 31] disabled
FirmwareRestart (Immediate)	Reboots the FC420 firmware.		firmwarerestart
Help (Immediate)	Displays a list of available commands. When the optional command name is present, detailed command-specific information is displayed.		help [command name]
IdentifyFibreBridge	Causes the Ready LED on the FC420 board to blink continuously until disabled.	disabled	set identifyfibrebridge [enabled disabled] get identifyfibrebridge
Info (Immediate)	Displays version numbers and other product information for key components within the FC420.		info
IPAddress	Sets/displays the current IP address of the FC420 bridge. If the ipdhcp command is enabled, the get command reports the current IP address assigned by the nameserver.	10.0.0.1	set ipaddress xxx.xxx.xxx.xxx get ipaddress
IPDHCP	Enables/disables the capability of the FC420 bridge to request an IP address from a DHCP server on the network.	enabled	set ipdhcp [enabled disabled] get ipdhcp
IPGateway	Sets/displays the current default gateway. If the ipdhcp command is enabled, the get command reports the current IP gateway assigned by the nameserver.	0.0.0.0	set ipgateway xxx.xxx.xxx.xxx get ipgateway

Command	Description	Default	Syntax
IPSubnetMask	Sets/displays the current subnet mask. If the <code>ipdhcp</code> command is enabled, the <code>get</code> command reports the current IP subnet mask assigned by the nameserver.	255.255. 255.0	set ipsubnetmask xxx.xxx.xxx.xxx get ipsubnetmask
IsReserved (Immediate)	Displays the reservation status of the current FC420 bridge services session/interface. When a reserve flag is set, the configuration image4 is undergoing modification by another FC420 bridge services session. Set commands are unavailable while in this state. Get commands are available, however. Executing a <code>saveconfiguration</code> , <code>restoreconfiguration</code> , or <code>firmwarerestart</code> command releases the reserved state so that other users may issue set commands.		isreserved
LogEvent	Sets the switches which control the filtering performed when logging events. The switches have the following meanings and settings: [enabled disabled] switch: controls whether or not events logging is enabled or disabled. [<i>subsystem</i>] switch: same as switch for <code>DispEvent</code> (see DispEvent on page 12) [<i>event_level</i>] switch: same as switch for <code>DispEvent</code> (see DispEvent on page 12) [<i>status</i>] switch: same as switch for <code>DispEvent</code> (see DispEvent on page 12)	disabled 3Fh 3Fh all	set logevent [enabled disabled] [[<i>subsystem</i>] [<i>event_level</i>] [<i>status</i>]] get logevent
MaxEnclTempAlrm	Sets/displays the maximum enclosure temperature alarm of the unit in degrees C (0-70 degrees C).	70°C	set maxencltempalrm [0-70] get maxencltempalrm
Menu	Enables/disables the menu interface. Entering the command alone without parameters toggles the current state.		menu <[enabled disabled]>
MinEnclTempAlrm	Sets/displays the minimum enclosure temperature alarm of the unit in degrees C (0-70 degrees C).	0°C	set minencltempalrm [0-70] get minencltempalrm

Command	Description	Default	Syntax
OEMConfigFile	Reports the name (i.e., the contents of the first record) of the OEM configuration file stored in persistent memory. This file is used to override the factory default configuration of the FC420 bridge.		get oemconfigfile
ParityLog	Resets/displays the parity error statistics for the FC420 bridge. The get command displays the statistics; the set command resets the statistic counters to zero.		set paritylog clear get paritylog
Performance	Returns the performance data for a user-specified Fibre port.		get performance <fp>
Reserve (Immediate)	Reservation of the FC420 is implicit; once the configuration image is changed by any user of services (Serial/Ethernet/Etc.), the FC420 becomes RESERVED. Performing a SaveConfiguration, RestoreConfiguration or FcRestart RELEASES the FC420 so that other devices may access it. When the FC420 services interface is reserved, set commands are unavailable, but get commands are available. Note that at least one service interface always has access to the FC420 at all times. This interface always reports a RELEASED status, since it may issue set commands.		reserve
RestoreConfiguration (Immediate)	Restore to factory default configuration or the last saved configuration. The new configuration must be saved to take effect.		restoreconfiguration [default saved]
RouteChange (Immediate)	Map a Fibre Channel port (<i>fp</i>) and LUN (<i>fl</i>) to a SCSI bus (<i>sb</i>), target (<i>st</i>), and LUN (<i>sl</i>). Valid route change entries are: <i>fp</i> (0) <i>fl</i> (0-31) <i>sb</i> (0-1) <i>st</i> (0-15) <i>sl</i> (0-7)		routechange [fp] [fl] [sb] [st] [sl]

Command	Description	Default	Syntax
RouteDisplay	List the currently mapped Fibre Channel-to-SCSI routes.		<pre>routedisplay routedisplay [fp] routedisplay [online offline] routedisplay [fp [fl]] routedisplay [fp [online offline]]</pre>
RouteOffline	Set the status of a route to offline.		<pre>set routeoffline [fp] [fl] get routeoffline [fp] [fl]</pre>
RouteOnline	Set the status of a route to online.		<pre>set routeonline [fp] [fl] get routeonline [fp] [fl]</pre>
SaveConfiguration (Immediate)	Save the new configuration. If a firmware restart is required to make the change, the user is prompted to confirm the restart. The user can override the confirmation request by indicating the override value on the command line.		<pre>saveconfiguration < restart nonrestart ></pre>
ScsiInitID	Specify the SCSI initiator ID to be used on the specified SCSI port.	0x07	<pre>set scsiinitid [sb [0-15]] get scsiinitid [sb]</pre>
ScsiPortBusSpeed	Specifies the transfer rate at which the FC420 bridge will attempt to negotiate with SCSI devices. The choices are Fast SCSI, Ultra SCSI, Ultra 2 SCSI, and Ultra 3 SCSI.	ultra3	<pre>set scsiportbusspeed [portnumber [fast ultra ultra 2 ultra3]] get scsiportbusspeed [portnumber]</pre>
ScsiPortList (Immediate)	List the available SCSI ports and their status.		<pre>scsiportlist</pre>
ScsiPortReset (Immediate)	Resets the specified SCSI bus.		<pre>scsiportreset [sb]</pre>
ScsiPortResetOnStartup	Specify whether the SCSI port should be reset on power-up.	enabled	<pre>set scsiportresetonstartup [sb [enabled disabled]] get scsiportresetonstartup [sb]</pre>

Command	Description	Default	Syntax
ScsiPortSelTimeout	Show the time (msec) that the bridge waits for a response from a SCSI device on the selected port after a selection request.	256 msec	set scsiportseltimeout [sb [256 128 64 32 16 8 4 2 1]] get scsiportseltimeout [sb]
ScsiPortSyncTransfer	Specify whether synchronous SCSI transfers should be negotiated with devices on the specified SCSI port.	enabled	set scsiportsynctransfer [[sb] [enabled disabled]] get scsiportsynctransfer [sb]
ScsiPortTaggedQueuing	Specify whether tagged command queuing is allowed on the SCSI port.	disabled	set scsiporttaggedqueuing [sb [enabled disabled]] get scsiporttaggedqueuing [sb]
ScsiPortWideTransfer	Specify whether wide SCSI transfers should be negotiated.	enabled	set scsiportwidetransfer [sb [enabled disabled]]
ScsiTargets	List the SCSI devices that are on the referenced SCSI bus.		get scsitargets [sb]
ScsiTermination	Set the internal termination of the referenced SCSI port.	enabled	set scsitermination [sb [enabled disabled]] get scsitermination [sb]
SerialNumber	Reports the FC420 bridge serial number.		get serialnumber
SerialPortBaudRate	Sets the baud rate for the FC420 serial port (2400, 9600, 19200, 38400, 57600, or 115200).	9600	set serialportbaudrate [rate] get serialportbaudrate
SerialPortEcho	Turn on or off echoing of keyboard input.	disabled	set serialportecho [enabled disabled]
SerialPortHandshake	Set the data handshaking method used for controlling the flow between the transmitter and receiver (hardware, software, or none).	none	set serialporthandshake [hard xon none] get serialporthandshake

Command	Description	Default	Syntax
SerialPortStopBits	Set the number of stop bits for the FC420 serial port (1 or 2).	1	set serialportstopbits [1 2] get serialportstopbits
ServicesLUN	Identifies the LUNs (one per Fibre port) to be used during an in-band command line interface (CLI) session with a given host. This information is taken from NVRAM. Any map coinciding with a user-specified ServicesLUN must first be set to offline before attempting to change the ServicesLUN. This map will be destroyed upon power-cycling the FC420 bridge. Disabling a ServicesLUN for a particular Fibre port will destroy the map to the FC420 bridge for that port.	8	set serviceslun [fp] [[f1] disabled] get serviceslun <[fp]>
SpeedWrite	Enables/disables SpeedWrite functionality to any SCSI device currently mapped to the FC420 bridge. To enable/disable SpeedWrite for a particular device, specify the SCSI bus (sb), the target (st), and the LUN (sl). Specify "all" to enable/disable this option for all currently mapped SCSI devices.		set speedwrite [sb st sl all] [enabled disabled] get speedwrite [sb st sl all]
SpeedWriteDefault	Enables/disables SpeedWrite functionality as a default condition when SCSI devices are mapped to the FC420 bridge.	disabled	set speedwritedefault [enabled disabled] get speedwritedefault
Temperature	Reports the unit temperature in degrees C.		get temperature
VerboseMode	Sets the Command Line Interface to display extended information about a parameter when the help command is given. When verbose mode is enabled, parameter values are generally preceded by labels in responses to the get commands. Only the parameter value is output when verbose mode is disabled.	enabled	set verbose [enabled disabled] get verbose

Command	Description	Default	Syntax
VirtualDriveResponse	Enables/disables the virtual drive response feature, which allows the FC420 bridge to provide proxy responses to SCSI INQUIRY and TEST UNIT READY commands in the event of a SCSI device selection time-out or busy event.	disabled	set virtualdriveresponse [enabled disabled] get virtualdriveresponse
XCDevices	Displays information about the devices used in a specified Extended Copy command. The <code>cmdnumber</code> variable is obtained using the <code>xcstatus</code> command. This command returns the following information: device type, vendor ID, product ID, serial number, and data direction.		get xcdevices [cmdnumber]
XCErrors	Retrieves any SCSI sense data returned by an Extended Copy command as the result of an error. The <code>cmdnumber</code> variable is obtained using the <code>xcstatus</code> command. This command returns the following information: SCSI status, sense key, ASC, and ASCQ. If a device involved in the command's data transfer also returned sense data, the device ID (serial number) along with sense data for the device will be displayed.		get xcerror [cmdnumber]
XCStatus	Allows the user to poll for the status of Extended Copy commands issued to the FC420 bridge. Each Extended Copy command is identified with a unique number. This number (called <code>cmdnumber</code>) is used when invoking the <code>xcdevices</code> and <code>xcerror</code> commands.		get xcstatus
Zmodem (Immediate)	Transfers a firmware image or NVRAM parameter file to or from the bridge using ZMODEM file transfer protocol.		zmodem [send [filename] receive]

FC420 Blink Codes

The Ready LED (see [figure 6](#)) on the FC420 bridge blinks to indicate the status of the FC420 board.

Figure 6 Primary Electronics Module with FC420 Bridge Installed

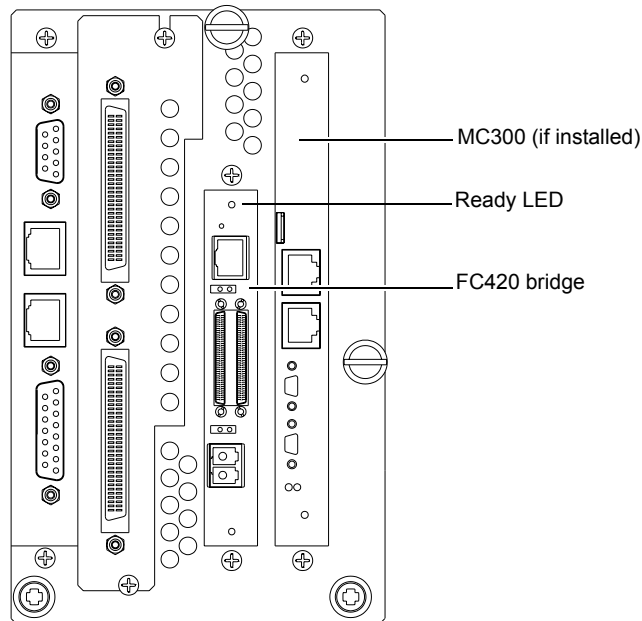

The Ready LED blinks in the following pattern:

- Long pause
- One or more blinks (Count these blinks; this is the *first blink digit*.)
- Short pause
- One or more blinks (Count these blinks; this is the *second blink digit*.)

[Table 3](#) provides meanings for these blink codes, listed by first and second blink digit.

Table 3 Blink Code
 Summary

First Blink Digit	Second Blink Digit	Error Code Classification	Failure	Recommended Action	Comments
1	1	Fatal	SCSI FW POST failure	Reboot board and record error log	
1	2	Fatal	CPU POST failure	Reboot board and record error log	
1	3	Fatal	RAM POST failure	Reboot board and record error log	
2	1	Fatal	SCSI chip POST failure	Reboot board and record error log	
2	2	Fatal	SRAM POST failure	Reboot board and record error log	
2	3	Fatal	Extended SRAM failure	Reboot board and record error log	
3	3	Fatal	DRAM POST failure	Reboot board and record error log	
3	4	Fatal	Extended DRAM failure	Reboot board and record error log	
4	1	Fatal	Fibre Channel controller	Reboot board and record error log	
4	2	Fatal/Non-fatal/Critical	Fibre Channel controller chip failure	Reboot board and record error log	Non-fatal in the case of port failover - if applicable (error code BC) Critical internal software incident, not a hardware defect (error code B3) Fatal internal software incident, not a hardware defect (error code B4)
4	3	Fatal	Fibre Channel controller chip initialization failure	Reboot board and record error log	

First Blink Digit	Second Blink Digit	Error Code Classification	Failure	Recommended Action	Comments
5	2	Fatal	SCSI controller chip 1 failure	Reboot board and record error log	
6	2	Fatal	SCSI controller chip 2 failure	Reboot board and record error log	
6	6	Critical	Temperature out of range	Reboot board	Board out of temperature range Correct operating temperature (cooling, etc.) prior to reboot.
7	1	Fatal	EOS panic code	Reboot board	Internal software incident, not a hardware defect
7	2	Fatal	Fibre Channel transceiver failure	Reboot board	
8	1	Fatal	Out of memory error	Reboot board	Internal software incident, not a hardware defect
8	3	Fatal	NVRAM checksum failure	Reboot board and check error log	Internal software incident, not a hardware defect (error code A4) Internal software incident, not a hardware defect (error code 93)
8	4	Fatal	MB system error	Reboot board and check error log	Internal software incident, not a hardware defect, reflash board (error codes 97, 99, and 9A) Internal software incidents, not hardware defects (error codes 9B, 9C, 9E, 9F, A0, and A1)

First Blink Digit	Second Blink Digit	Error Code Classification	Failure	Recommended Action	Comments
8	5	Fatal	Ethernet failure	Reboot board and check error log	Internal software incident, not a hardware defect (error code 98) Internal software incident, not a hardware defect (error code B5)
8	6	Fatal	Parity failure	Reboot board and check error log	
8	7	Fatal	ECC failure	Reboot board and check error log	
8	9	Critical		Reboot, perform <code>hdwzinfo</code> command at reboot and return information to Quantum	Internal SW incident, not a hardware defect
9	3	Non-fatal	SES identification failure	Reboot board and check error log	
9	4	Fatal	SES fault requested	Reboot board and check error log	Fault requested via SES

Configuring FC420 Firmware

Each FC420 bridge installed must be configured using the FC420 Bridge Services software. To configure the FC420 bridge successfully, it is important to:

- Know exactly how the SCSI cabling in the library is configured, including:
 - How many FC420 bridges are present in the library
 - How many SCSI buses are present in the library
 - How many SCSI devices are connected to each bus (this was established in the previous section of this document)
- Use the FC420 Bridge Services software to create a Map file identifying which SCSI devices are connected to which Fibre Channel ports on the FC420 board

The major steps for manually configuring FC420 bridge firmware are:

Note: If you have an MC300 PMC, refer to the *MC300 Prism Management Card User's Guide, PN 6473040*, to configure your FC420 bridge (or bridges), instead of the following steps.

- [Setting Up an Ethernet Connection](#)
- [Verifying Current FC420 Firmware](#)
- [Scanning the SCSI Busses on the Library](#)
- [Creating a Map File for the FC420](#)

Note: These major steps must be repeated for each FC420 bridge in the library.

Setting Up an Ethernet Connection

To set up an Ethernet connection between the FC420 bridge and a service PC or other stand-alone computer equipped with Windows or Windows NT:

Note: The FC420 bridge has DHCP enabled, which searches for a server to get an address. The DHCP server for this application is the MC300 PMC, which is the default. If you have an MC300 PMC, do not perform this procedure, refer to the *MC300 Prism Management Card User's Guide, PN 6473040* for FC420 bridge administration.

- 1 Connect a Field Service Notebook to the FC420.
 - a Turn on the Field Service Notebook.
 - b Disconnect the Ethernet cable to the FC420 bridge.
 - c Power-cycle the library.
 - d Wait five minutes.
- 2 After the five minute wait period, attach one end of a CAT-5 crossover cable to the RJ-45 connector at the top of the FC420 bridge.
- 3 Attach the other end of the CAT-5 crossover cable to the NIC port on the computer.

This establishes a physical connection between the FC420 bridge and the computer.
- 4 Right-click the network icon on the computer's desktop.

In some versions of Windows, this icon may be labeled **Network Neighborhood**. In other versions of Windows, this icon may be labeled **My Network Places** or something similar.

Windows displays a pop-up menu.

- 5 On the pop-up menu, select **Properties**.

Windows displays a **Network** dialog box.

- 6 Click the **Protocols** (Windows NT) or right-click the connection and select **Properties** (Windows 2000 or later) tab.

- 7 Double-click the **TCP/IP Protocol** menu item.

Windows displays the **TCP/IP Properties** dialog box.

Note: Make a note of the current network settings before changing them. You will need this information if you wish to return the computer to its previous configuration after configuring the FC420 bridge.

- 8 Select the option that allows you to specify an IP address.

In some version of Windows this option is shown as **Specify an IP Address**. In other versions of Windows, this option is shown as **Use the Following IP Address**.

The **IP Address**, **Subnet Mask**, and **Gateway** fields become active.

- 9 In the **IP Address** field, type 10.0.0.x (where x is a number between 2 and 253).
- 10 In the **Subnet Mask** field, type 255.255.255.0.

Note: Do not type anything in the **Gateway** field.

- 11 Click **OK** until all the dialog boxes close.

- 12 If you are using Windows NT, open a DOS window and type:

```
ipconfig/release <Enter>  
ipconfig/renew <Enter>
```

Note: This step is not required for other versions of Windows.

- 13 Turn on the library.

- 14 Establish a Telnet connection to the FC420 bridge. To do this:

- a Start a Telnet session from the computer desktop by selecting **Start > Run**.

- b** In the **Run** dialog box, type `telnet 10.0.0.1` and then click **OK**.

The Telnet window opens, indicating a connection with the FC420 bridge. When you see a Ready prompt, command line mode is available.

Verifying Current FC420 Firmware

To determine the current version of FC420 firmware, type `info` at the Ready prompt and then press <Enter>. This command returns the firmware version and gives the firmware revision date. Use this information to determine the firmware version of the FC420 bridge.

To perform a firmware update, follow these steps:

- 1** Contact your support representative to determine if a version update is required.
- 2** If you have not done so already, establish an Ethernet connection between the computer with the new FC420 driver and the FC420 bridge to be updated (see [Setting Up an Ethernet Connection](#)).
- 3** On the computer, open a command prompt window.
- 4** In the command prompt window, type `ftp FC420_IP_address` (where *FC420_IP_address* is the IP address for the FC420 bridge) and then press <Enter>.

Note: Before entering the FTP command, close all prior connections to the FC420.

- 5** When prompted for a username, type `sysadmin` (or the current system administrator ID) and then press <Enter>.
- 6** When prompted for a password, type `sysadmin` (or the current system administrator ID) and then press <Enter>.
- 7** At the command line, type `bin` and then press <Enter>.
- 8** At the command line, type `put firmware_filename` (where *firmware_filename* is the name of the firmware file) and then press <Enter>.

Several messages appear on the screen. Finally, a success message appears.

- 9** Type `bye` or `quit` and then press <Enter>.
- 10** Power cycle the library.

Scanning the SCSI Busses on the Library

To confirm that the SCSI buses are cabled properly:

- 1** At the Ready prompt, type `scsitargets 0`, and then press <Enter>.

This command scans and displays all SCSI devices found on SCSI bus 0.

- 2 If the second SCSI port on the FC420 bridge is being utilized, wait for the Ready prompt to reappear, then type `scsitargets 1` and press <Enter>.

Creating a Map File for the FC420

Each FC420 bridge in the library requires a map file to identify the SCSI devices in the library electronically connected to each Fibre Channel port on the board.

To create the FC420 Map, perform the following steps:

- 1 At the Ready prompt, type `scsiportlist` and then press <Enter>. This command returns a list of available SCSI ports and their current status.
- 2 If there are no SCSI bus failures, type `automap` and press <Enter>. The `automap` command executes.
- 3 When the Ready prompt reappears, type `saveconfiguration` and press <Enter>.
- 4 When the Ready prompt reappears, type `firmwarerestart` and press <Enter>.

Making Other Configuration Changes

The preceding firmware configuration steps are mandatory to ensure successful library operation. After completing these procedures, you may want to make other configuration changes by issuing additional service commands.

Service Command List

For your convenience, all service commands for the FC420 bridge are listed in [FC420 Services Software Commands](#).

Using the Help Command

You can also obtain a list of service commands by typing `help` and then pressing <Enter>.

To get more information about a particular command, type `help command_name` and then press <Enter>, where *command_name* is the exact name of the command about which you want information.

Restoring the PC to Its Original Configuration

Once you have finished configuring the FC420 bridge, return the PC to its original configuration by opening the **TCP/IP Properties** dialog box and return the network settings to their original values.

Made in the USA.

Quantum Corporation provides this publication "as is" without warranty of any kind, either express or implied, including but not limited to the implied warranties of merchantability or fitness for a particular purpose. Quantum Corporation may revise this publication from time to time without notice.

COPYRIGHT STATEMENT

© Copyright 2003 by Quantum Corporation. All rights reserved.

Your right to copy this document is limited by copyright law. Making copies or adaptations without prior written authorization of Quantum Corporation is prohibited by law and constitutes a punishable violation of the law.

TRADEMARK STATEMENT

StackLink is a trademark of Quantum Corporation.

Sun StorEdge™ L25 Tape Library and Sun StorEdge™ L100 Tape Library are trademarks of Sun Microsystems, Inc.

Other trademarks may be mentioned herein which belong to other companies.