

L700e Tape Library

Operator's Guide





L700e Tape Library

Operator's Guide

Information contained in this publication is subject to change without notice. Comments concerning the contents of this publication should be directed to:

Information Development
 Storage Technology Corporation
 One StorageTek Drive
 Louisville, CO 80028-2201
 USA

URL: <http://sts.storitek.com/sts/nid>

Complete the following table in pencil (or make a copy) to record your configuration.

L700 Tape Library Configuration Information	
Serial Number: _____	Code Version: _____
Library ID: _____	
Number of Drives Installed: _____	
DLT7000	Single-ended <input type="checkbox"/> Differential <input type="checkbox"/> On bus <input type="checkbox"/> Off bus <input type="checkbox"/> Address: _____ _____
DLT8000	Single-ended <input type="checkbox"/> Differential <input type="checkbox"/> On bus <input type="checkbox"/> Off bus <input type="checkbox"/> Address: _____ _____
9840/T9840B/T9940	Differential <input type="checkbox"/> Fiber Channel <input type="checkbox"/> On bus <input type="checkbox"/> Off bus <input type="checkbox"/> Address: _____
Ultrium	Single-ended <input type="checkbox"/> Differential <input type="checkbox"/> HVD <input type="checkbox"/> LVD <input type="checkbox"/> On bus <input type="checkbox"/> Off bus <input type="checkbox"/> Address: _____ _____
Fast Load: Enabled <input type="checkbox"/> Disabled <input type="checkbox"/>	Auto Clean: Enabled <input type="checkbox"/> Disabled <input type="checkbox"/>

StorageTek, the signature, and Information Made Powerful are trademarks of Storage Technology Corporation. Other product names, features, and terms used in this publication are for informational purposes only and might be trademarks of Storage Technology Corporation or of other companies.

©1999, 2001 by Storage Technology Corporation, Louisville, Colorado, USA. All rights reserved. Printed in the USA.

Summary of Changes

EC	Date	Edition	Description
53897	August 1999	First	Initial Release
111626	April 2001	Ninth	Refer to this and previous editions for a description of the changes.
111677	August 2001	Tenth	General: Changed book title to reflect frame change from L700 to L700e. Appendix A: Revised cartridge tape and label information to include SDLT cartridges.

This page intentionally left blank.

Contents

Summary of Changes	iii
Contents	v
Figures	x
Tables	xii
Preface	xiii
Organization	xiii
Alert Messages	xiv
Conventions	xiv
Additional Information	xv
StorageTek's External Web Site	xv
Customer Resource Center	xv
e-Partners Site	xvi
Hardcopy Publications	xvi
Comments and Suggestions	xvi
Notices	xvii
FCC Compliance Statement	xvii
CISPR 22 and EN55022 Warning	xvii
Japanese Compliance Statement	-xviii
Taiwan Warning Label Statement	-xviii
Internal Code License Statement	xix
Safety	xxi
Fiber Optic Safety	xxi
Laser Product Label	xxi
Fiber-Optic Cable Handling	xxii
Fiber-Optic Cable Installation	xxii
Rack Safety and Precautions	xxiii
Electrostatic Discharge Damage Prevention	xxvi
1: General Information	1-1
Tape Library Components	1-1
Robot	1-3
Storage Cells	1-5
Cell Locations	1-5

Library Capacity	1-5
Reserved Cells	1-9
Cartridge Access Port	1-10
Drives	1-11
Horizon L Series Library Monitor Feature	1-12
Tape Library Safety Features	1-12
Controlling Software	1-12
Library Operating Modes	1-12
Automated Mode	1-13
Manual Mode	1-13
Auto Clean Feature	1-13
13U Rack Area	1-14
2: Controls and Indicators	2-1
Operator Panel	2-1
Indicators	2-3
Buttons	2-3
Display Screens	2-3
Library Status	2-4
FSC (Fault Symptom Code) Logs	2-6
CAP Contents	2-7
Drive Information	2-8
Cleaning Information	2-9
Diagnostic Tests	2-10
Version Information	2-11
Main Configuration Menu	2-12
Library Configuration	2-12
Library SCSI Interface Configuration	2-13
Library Fibre Channel Interface Configuration	2-13
Drive Configuration	2-14
Network Configuration	2-15
Personality Module	2-16
Display Information	2-16
Operations Overview	2-17
Library Power Switch	2-18
Redundant AC Power Option	2-20
Tape Drive Power Switches	2-21
3: Configuration	3-1
Enabling Auto Clean	3-1
Powering on the Library	3-2
Initializing and IPLing the Library	3-3

Re-initializing the Library	3-3
Re-IPLing the Library	3-3
Entering Configuration Data	3-3
Operator Panel Entry	3-4
Library Entries	3-4
Setting the Library's SCSI ID	3-4
Setting the Library Fibre Channel Port 0 Address	3-5
Reviewing Port 0 Worldwide ID	3-7
Reviewing Library Worldwide ID	3-7
Enabling/Disabling Fast Load	3-7
Setting the Date	3-8
Setting the Time	3-9
Configuring a Personality Module	3-9
Setting the Web Password	3-9
Drive Entries (SCSI Drives Only)	3-10
Network Entries	3-12
Viewing the Ethernet Address	3-12
Setting the Library Name	3-12
Setting the IP Address	3-13
Setting the Network Gateway Address	3-14
Setting the Subnet Mask Address	3-15
Screen Characteristics	3-15
Cleaning Cartridge Warning Count	3-16
Horizon L Series Library Monitor Entries (Optional)	3-17
Loading Tapes into the Library	3-18
Placing the Library Online	3-20
Sending Library Audit Data to the Client	3-20
4: Library Operation	4-1
Operating in Automated Mode	4-1
Monitoring Status Information	4-1
CAP Status	4-2
Library Status	4-3
Remote Users Status	4-3
Drive Status	4-3
Drive Information	4-4
CAP Magazine Status	4-5
CAP States	4-5
Cleaning Cartridge Usage Count	4-6
Cartridges in the Reserved Cells	4-6
Cartridges in Reserved Cells and CAP	4-6
Library Personality Information	4-7

Exporting Cleaning Cartridges through the CAP	4-9
Importing Cleaning Cartridges through the CAP	4-9
Importing Data Cartridges through the CAP	4-11
Exporting Data Cartridges through the CAP	4-16
Manually Cleaning a Drive	4-16
Reviewing FSC Logs	4-17
Running Diagnostic Tests	4-18
Running Drive Diagnostic Tests	4-19
Running a Get-Put Loop	4-19
Operating in Demo Mode	4-20
Powering off the Library	4-21
Operating in Manual Mode	4-22
Opening the Library Front Doors	4-22
Moving the Robot	4-23
Raising and Lowering the Hand-camera Assembly	4-24
Rotating the Z Column	4-25
Locating a Cartridge in the Storage Cells	4-25
Removing a Cartridge from the Hand	4-26
Loading/Unloading Cartridges Manually	4-28
Loading a Cartridge into a Load Handle Drive	4-28
Unloading a Cartridge from a Load Handle Drive	4-30
Loading a Cartridge into a 9840/T9840B/T9940 Drive	4-31
Unloading a Cartridge from a 9840/T9840B/T9940 Drive	4-32
Loading a Cartridge into an Ultrium Drive	4-33
Unloading a Cartridge from an Ultrium Drive	4-34
Returning the Library to Online Status	4-35
5: StorageTek Maintenance Support	5-1
Customer Support Services	5-1
Customer Initiated Maintenance	5-1
StorageTek's Worldwide Offices	5-2
A: Cartridge Tape Information	A-1
Cartridge Tapes and Labels	A-1
Cleaning and Diagnostic Cartridge Starter Kits	A-2
Cartridge and Label Part Numbers	A-3
Colored Cartridge Specifications	A-4
Preparing Cartridges	A-4
Handling a Cartridge	A-4
Inspecting a Cartridge	A-5
Ordering Tape Cartridges/Labels	A-9
Applying Cartridge Labels to DLT Cartridges	A-10

Applying Cartridge Labels to 9840/T9840B Cartridges	A-12
Applying Cartridge Labels to T9940 Cartridges	A-13
Applying Cartridge Labels to Ultrium Cartridges	A-14
Setting the DLT and SDLT Write-protect Switch	A-15
Setting the 9840/T9840B Write-protect Switch	A-16
Setting the T9940 Write-protect Switch	A-17
Setting the Ultrium Write-protect Switch	A-18
Maintaining Cartridges	A-19
DLT Cartridge Environmental Specifications	A-19
9840/T9840B Cartridge Environmental Specifications	A-20
Ultrium Cartridge Environmental Specifications	A-21
Storage of Cartridges	A-22
Cartridge Exterior—Cleaning	A-22
Repair of a Detached Leader Block	A-22
B: Library Elements and Diagrams	B-1
Glossary	Glossary-1
Index.	Index-1
Reader's Comment Form	RCF-1

Figures

Figure 1-1. Library Major External Components	1-2
Figure 1-2. Robot Components	1-4
Figure 1-3. Locating Cartridges—Top View	1-7
Figure 1-4. Locating Cartridges—Panels, Cells, Rows	1-8
Figure 1-5. Reserved Cell Locations	1-10
Figure 2-1. Operator Panel Display, Controls, and Indicators	2-2
Figure 2-2. Library Initial Status Screen	2-5
Figure 2-3. Main Menu Screen	2-5
Figure 2-4. FSC Log Screen	2-6
Figure 2-5. CAP Status Screen	2-7
Figure 2-6. Drive Information Menu	2-8
Figure 2-7. Cleaning Information Menu	2-10
Figure 2-8. Main Diagnostics Menu	2-11
Figure 2-9. Version Information Menu	2-11
Figure 2-10. Main Configuration Menu	2-12
Figure 2-11. Library Configuration Menu	2-13
Figure 2-12. Library SCSI Interface Configuration Menu	2-13
Figure 2-13. Library Fibre Channel Interface Configuration Menu	2-14
Figure 2-14. Drive Configuration Menu	2-15
Figure 2-15. Network Configuration Menu	2-15
Figure 2-16. Personality Module Information	2-16
Figure 2-17. Display Information Menu	2-16
Figure 2-18. Library Power Switch Location	2-19
Figure 2-19. Drive Power Switch Locations	2-21
Figure 3-1. Placing Tapes into Array Cells—9840, T9840B and T9940	3-18
Figure 3-2. Placing Tapes into Array Cells—Ultrium, DLT, and SDLT	3-19
Figure 4-1. Example Library Status Screen	4-2
Figure 4-2. Removing the CAP Magazine	4-12
Figure 4-3. Entering DLT/SDLT Cartridges into the CAP Magazine	4-13
Figure 4-4. Entering 9840/T9840B/T9940 Cartridges into the CAP Magazine	4-14
Figure 4-5. Entering Ultrium Cartridges into the CAP Magazine	4-15
Figure 4-6. Opening the Access Doors	4-23
Figure 4-7. Raising and Lowering the Hand-camera Assembly	4-24
Figure 4-8. Rotating the Z Column	4-25
Figure 4-9. Extending the Gripper	4-26
Figure 4-10. Removing a Cartridge from the Hand	4-27

Figure 4-11. Drive with Load Handle 4-29

Figure 4-12. Loading a Cartridge into a Load Handle Drive 4-30

Figure 4-13. Loading a Cartridge into the 9840/T9840B/T9940 Drive 4-32

Figure 4-14. Loading a Cartridge into an Ultrium Drive 4-34

Figure A-1. DLT and SDLT Cartridge Components A-5

Figure A-2. 9840/T9840B Cartridge Components A-6

Figure A-3. T9940 Cartridge Components A-7

Figure A-4. Ultrium Cartridge Components A-8

Figure A-5. Applying Cartridge Labels to DLT and SDLT Cartridges A-11

Figure A-6. Applying Cartridge Labels to 9840/T9840B Cartridges A-12

Figure A-7. Applying Cartridge Labels to T9940 Cartridges A-13

Figure A-8. Ultrium Cartridge Label A-14

Figure A-9. Setting the DLT and SDLT Write-protect Switch A-15

Figure A-10. Setting the 9840/T9840B Write-protect Switch A-16

Figure A-11. Setting the T9940 Write-protect Switch A-17

Figure A-12. Setting the Ultrium Write-protect Switch A-18

Figure B-1. Tape Library Elements—1 CAP, 1 Drive Column B-2

Figure B-2. Tape Library Elements—1 CAP, 2 Drive Columns B-3

Figure B-3. Tape Library Elements—2 CAPs, 1 Drive Column B-4

Figure B-4. Tape Library Elements—2 CAPs, 2 Drive Columns B-5

Tables

Table 1-1. Tape Library Capacity	1-6
Table 2-1. Operations Guide	2-17
Table 4-1. CAP Status Messages	4-2
Table 4-2. Library Status Messages	4-3
Table 4-3. Drive Status Messages	4-3
Table 4-4. CAP Magazine Slot Status Messages	4-5
Table 4-5. CAP States	4-5
Table 4-6. Personality Module Status/Info Screen	4-8
Table 4-7. L700e Library Drive Diagnostic Tests	4-18
Table A-1. Cleaning and Diagnostic Cartridge Starter Kits	A-2
Table A-2. Cartridge and Label Part Numbers	A-3
Table A-3. Ultrium Cartridge Codes	A-8
Table A-4. Ultrium Cartridge Models	A-9
Table A-5. DLT Cartridge Environmental Specifications	A-19
Table A-6. 9840/T9840B Cartridge Environmental Specifications	A-20
Table A-7. LTO Ultrium Cartridge Environmental Specifications	A-21

Preface

This guide describes how to operate the L700e tape library (referred to in this manual as “the library”). For specific drive information and for host-generated software commands and console messages, refer to your drive or software documentation.

This guide is intended primarily for data center operators. System programmers and computer system administrators might also find the information useful.

■ Organization

This guide has five chapters and two appendixes:

- Chapter 1** “General Information” describes the tape library hardware. This chapter also describes the library’s two operating modes, its Auto Clean feature, and the optional Horizon L Series Library Monitor.
- Chapter 2** “Controls and Indicators” shows the locations of the power switch and operator panel and describes the functions of the buttons, indicators, and display screens.
- Chapter 3** “Configuration” describes how to power on and configure the library and drives through the operator panel.
- Chapter 4** “Library Operation” contains the procedures for operating the library in two modes: automated mode and manual mode. It explains how to load cartridges through the CAP, power off the library, and manually removing cartridges.
- Chapter 5** “StorageTek Maintenance Support” describes how to contact the Customer Support Center for assistance if the library has a hardware or software problem.
- Appendix A** “Cartridge Tape Information” describes how to prepare, inspect, store, clean, and repair cartridges. It also lists the criteria that colored cartridges must meet to be used in the tape library.
- Appendix B** “Library Elements and Diagrams” includes maps of all SCSI elements and panel, row, column locations for the library cells.
- Glossary** The [Glossary](#) defines new or special L700e tape library terms and abbreviations used in this guide.
- Index** The [Index](#) assists in locating information in this guide.

■ Alert Messages

Alert messages call the reader's attention to information that is especially important or that has a unique relationship to the main text or graphic.

Note: A note provides additional information that is of special interest. A note might point out exceptions to rules or procedures. A note usually, but not always, follows the information to which it pertains.

CAUTION:

A caution informs the reader of conditions that might result in damage to hardware, corruption of data, corruption of application software, or long-term health problems in people. A caution always precedes the information to which it pertains.

A warning alerts the reader to conditions that might result in injury or death. A warning always precedes the information to which it pertains.

■ Conventions

Typographical conventions highlight special words, phrases, and actions in this publication.

Item	Example	Description of Convention
Acronyms	CSA	All uppercase
Buttons	MENU	Sans serif font; capitalization follows label on product (usually all uppercase)
Commands	Mode Select	Initial cap
Document titles	<i>System Assurance Guide</i>	Italic font
Emphasis	<i>not</i> or <i>must</i>	Italic font
File names	fsc.txt	Monospace font
Hypertext links	Figure 2-1 on page 2-5	Blue (prints black in hardcopy publications)
Indicators	<i>Open</i>	Italic font; capitalization follows label on product (usually initial caps)
Jumper names	TERMPWR	All uppercase
Keyboard keys	<Y> <Enter> or <Ctrl+Alt+Delete>	Sans serif font; capitalization follows label on product (usually initial caps); enclosed within angle brackets

Item	Example	Description of Convention
Menu names	Configuration Menu	Capitalization follows label on product; usually title caps
Parameters and variables	Device = <i>xx</i>	Italic font
Path names	c:/mydirectory	Monospace font
Port or connector names	SER1	Capitalization follows label on product; otherwise, all uppercase
Positions for circuit breakers, jumpers, and switches	ON	Default font; capitalization follows label on product; otherwise, all uppercase
Screen text (including screen captures, screen messages, and user input)	downloading	Monospace font
Switch names	Power	Sans serif font; capitalization follows label on product
URLs	http://www.storagetek.com	Blue (prints black in hardcopy publications)

■ Additional Information

StorageTek offers several methods for you to obtain additional information. Please use one of these methods when you want to obtain the latest edition of this or any other StorageTek customer publication.

StorageTek's External Web Site

StorageTek's external Web site provides marketing, product, event, corporate, and service information. In addition, the external Web site serves as an entry point to the Customer Resource Center (CRC) and to the e-Partners site. The external Web site is accessible to anyone with a Web browser and an Internet connection.

The URL for the StorageTek external Web site is <http://www.storagetek.com>

Customer Resource Center

StorageTek's Customer Resource Center (CRC) is a Web site that enables members to resolve technical issues by searching code fixes and technical documentation. CRC membership entitles you to other proactive services, such as HIPER subscriptions, technical tips, answers to frequently asked questions, and online product support contact information. Customers who have a current warranty or a current maintenance service agreement may apply for

membership by clicking on the Request Password button on the CRC home page.

The URL for the CRC is <http://www.support.storagetek.com>.

e-Partners Site

StorageTek's e-Partners site, formerly known as the Partners Page or the Channels Site, is a Web site that provides information about products, services, customer support, upcoming events, training programs, and sales tools to support StorageTek's e-Partners. Access to this site, beyond the e-Partners Login page, is restricted. On the e-Partners Login page, current partners who do not have access can request a login ID and password and prospective partners can apply to become StorageTek resellers.

The URL for the e-Partners site is <http://channels.stortek.com>.

Hardcopy Publications

Contact a StorageTek sales or marketing representative to order additional paper copies of this publication or to order other StorageTek customer publications in paper format.

■ Comments and Suggestions

A Reader's Comment Form at the back of this publication lets you communicate suggestions or requests for change. StorageTek encourages and appreciates reader feedback.

Notices

Please read the following compliance and warning statements for this product.

CAUTION:

***Potential equipment damage:* Cables that connect peripherals must be shielded and grounded; refer to cable descriptions in the instruction manuals. Operation of this equipment with cables that are not shielded and not correctly grounded might result in interference to radio and TV reception.**

Changes or modifications to this equipment that are not expressly approved in advance by StorageTek will void the warranty. In addition, changes or modifications to this equipment might cause it to create harmful interference.

■ FCC Compliance Statement

The following compliance statement pertains to Federal Communications Commission Rules 47 CFR 15.105:

Note: This equipment has been tested and found to comply to the limits for Class A digital devices pursuant to part 15 of the FCC Rules. These limits are designed to provide reasonable protection against harmful interference when the equipment is operated in a commercial environment. This equipment generates, uses, and can radiate radio frequency energy and, if not installed in accordance with the instruction manual, may cause harmful interference to radio communications. Operation of this equipment in a residential area is likely to cause harmful interference, in which case the user will be required to correct the interference at his or her own expense.

■ CISPR 22 and EN55022 Warning

This is a Class A product. In a domestic environment, this product may cause radio interference, in which case, the user may be required to take adequate measures.

■ Japanese Compliance Statement

The following compliance statement in Japanese pertains to VCCI EMI regulations:

この装置は、情報処理装置等電波障害自主規制協議会（VCCI）の基準に基づくクラスA情報技術装置です。この装置を家庭環境で使用すると電波妨害を引き起こすことがあります。この場合には使用者が適切な対策を講ずるよう要求されることがあります。

English translation: This is a Class A product based on the standard of the Voluntary Control Council for Interference by Information Technology Equipment (VCCI). If this equipment is used in a domestic environment, radio disturbance may occur, in which case, the user may be required to take corrective actions.

■ Taiwan Warning Label Statement

The following warning label statement pertains to BSMI regulations in Taiwan, R.O.C.:

警告使用者: 這是甲類的資訊產品，在居住的環境中使用時，可能會造成射頻干擾，在這種情況下，使用者會被要求採取某些適當的對策。

English translation: This is a Class A product. In a domestic environment, this product may cause radio interference, in which case, the user may be required to take adequate measures.

■ Internal Code License Statement

The following is the Internal Code License Agreement from StorageTek:

NOTICE

INTERNAL CODE LICENSE

PLEASE READ THIS NOTICE CAREFULLY BEFORE INSTALLING AND OPERATING THIS EQUIPMENT. THIS NOTICE IS A LEGAL AGREEMENT BETWEEN YOU (EITHER AN INDIVIDUAL OR ENTITY), THE END USER, AND STORAGE TECHNOLOGY CORPORATION ("STORAGETEK"), THE MANUFACTURER OF THE EQUIPMENT. BY OPENING THE PACKAGE AND ACCEPTING AND USING ANY UNIT OF EQUIPMENT DESCRIBED IN THIS DOCUMENT, YOU AGREE TO BECOME BOUND BY THE TERMS OF THIS AGREEMENT. IF YOU DO NOT AGREE WITH THE TERMS OF THIS AGREEMENT, DO **NOT** OPEN THE PACKAGE AND USE THE EQUIPMENT. IF YOU DO NOT HAVE THE AUTHORITY TO BIND YOUR COMPANY, DO **NOT** OPEN THE PACKAGE AND USE THE EQUIPMENT. IF YOU HAVE ANY QUESTIONS, CONTACT THE AUTHORIZED STORAGETEK DISTRIBUTOR OR RESELLER FROM WHOM YOU ACQUIRED THIS EQUIPMENT. IF THE EQUIPMENT WAS OBTAINED BY YOU DIRECTLY FROM STORAGETEK, CONTACT YOUR STORAGETEK REPRESENTATIVE.

1. **Definitions:** The following terms are defined as followed:
 - a. "Derivative works" are defined as works based upon one or more preexisting works, such as a translation or a musical arrangement, or any other form in which a work may be recast, transformed, or adapted. A work consisting of editorial revision, annotations, elaboration, or other modifications which, as a whole, represent an original work of authorship, is a Derivative work.
 - b. "Internal Code" is Microcode that (i) is an integral part of Equipment, (ii) is required by such Equipment to perform its data storage and retrieval functions, and (iii) executes below the user interface of such Equipment. Internal code does not include other Microcode or software, including data files, which may reside or execute in or be used by or in connection with such Equipment, including, without limitation, Maintenance Code.
 - c. "Maintenance Code" is defined as Microcode and other software, including data files, which may reside or execute in or be used by or in connection with Equipment, and which detects, records, displays, and/or analyzes malfunctions in the Equipment.
 - d. "Microcode" is defined as a set of instructions (software) that is either imbedded into or is to be loaded into the Equipment and executes below the external user interface of such Equipment. Microcode includes both Internal Code and Maintenance Code, and may be in magnetic or other storage media, integrated circuitry, or other media.
2. The Equipment you have acquired by purchase or lease is manufactured by or for StorageTek and contains Microcode. By accepting and operating this Equipment, you acknowledge that StorageTek or its licensor(s) retain(s) ownership of all Microcode, as well as all copies thereof, that may execute in or be used in the operation or servicing of the Equipment and that such Microcode is copyrighted by StorageTek or its licensor(s).
3. StorageTek hereby grants you, the end user of the Equipment, a personal, nontransferable (except as permitted in the transfer terms in paragraph 7 below), nonexclusive license to use each copy of the Internal Code (or any replacement provided by StorageTek or your authorized StorageTek distributor or reseller) which license authorizes you, the end user, to execute the Internal Code solely to enable the specific unit of Equipment for which the copy of Internal Code is provided to perform its data storage and retrieval functions in accordance with StorageTek's (or its licensor's) official published specifications.
4. Your license is limited to the use of the Internal Code as set forth in paragraph 3 above. You may not use the Internal Code for any other purpose. You may not, for example, do any of the following:
 - (i) access, copy, display, print, adapt, alter, modify, patch, prepare Derivative works of, transfer, or distribute (electronically or otherwise) or otherwise use the Internal Code;
 - (ii) reverse assemble, decode, translate, decompile, or otherwise reverse engineer the Internal Code (except as decompilation may be expressly permitted under applicable European law solely for the purpose of gaining information that will allow

interoperability when such information is not otherwise readily available); or

(iii) sublicense, assign, or lease the Internal Code or permit another person to use such Internal Code, or any copy of it.

If you need a backup or archival copy of the Internal Code, StorageTek, or your authorized StorageTek distributor or reseller, will make one available to you, it being acknowledged and agreed that you have no right to make such a copy.

5. Nothing in the license set forth in paragraph 3 above or in this entire Notice shall convey, in any manner, to you any license to or title to or other right to use any Maintenance code, or any copy of such Maintenance Code. Maintenance Code and StorageTek's service tools and manuals may be kept at your premises, or they may be supplied with a unit of Equipment sent to you and/or included on the same media as Internal Code, but they are to be used only by StorageTek's customer service personnel or those of an entity licensed by StorageTek, all rights in and to such Maintenance Code, service tools and manuals being reserved by StorageTek or its licensors. You agree that you shall not use or attempt to use the Maintenance Code or permit any other third party to use and access such Maintenance Code.
6. You, the end user, agree to take all appropriate steps to ensure that all of your obligations set forth in this Notice, particularly in paragraphs 4 and 5, are extended to any third party having access to the Equipment.
7. You may transfer possession of the Internal Code to another party only with the transfer of the Equipment on which its use is authorized, and your license to use the Internal Code is discontinued when you are no longer an owner or a rightful possessor of the Equipment. You must give such transferee all copies of the Internal Code for the transferred Equipment that are in your possession, along with a copy of all provisions of this Notice. Any such transfer by you is automatically (without further action on the part of either party) expressly subject to all the terms and conditions of this Notice passing in full to the party to whom such Equipment is transferred, and such transferee accepts the provisions of this license by initial use of the Internal Code. You cannot pass to the transferee of the Equipment any greater rights than granted under this Notice, and shall hold StorageTek harmless from any claim to the contrary by your transferee or its successors or assigns. In addition, the terms and conditions of this Notice apply to any copies of Internal Code now in your possession or use or which you hereafter acquire from either StorageTek or another party.
8. You acknowledge that copies of both Internal Code and Maintenance Code may be installed on the Equipment before shipment or included with the Equipment and other material shipped to you, all for the convenience of StorageTek's service personnel or service providers licensed by StorageTek, and that during the warranty period, if any, associated with the Equipment, and during periods in which the Equipment is covered under a maintenance contract with StorageTek or service providers licensed by StorageTek, both Internal Code and Maintenance Code may reside and be executed in or used in connection with such Equipment, and you agree that no rights to Maintenance Code are conferred upon you by such facts. StorageTek or the licensed service provider may keep Maintenance Code and service tools and manuals on your premises but they are to be used only by StorageTek's customer service personnel or those of service providers licensed by StorageTek. You further agree that upon (i) any termination of such warranty period or maintenance contract period; or (ii) transfer of possession of the Equipment to another party, StorageTek and its authorized service providers shall have the right with respect to the affected Equipment to remove all service tools and manuals and to remove or disable all Maintenance Code and/or replace Microcode which includes both Internal Code and Maintenance Code with Microcode that consists only of Internal Code.

Safety

To ensure your safety, please read the following information.

■ Fiber Optic Safety

WARNING:

***Eye hazard.* Never look directly into a fiber-optic cable, a fiber-optic connector, or a laser transceiver module. Hazardous conditions might exist from laser power levels that are capable of causing injury to the eye.**

Be especially careful when using optical instruments with this equipment. Such instruments might increase the likelihood of eye injury.

The laser transceivers in fiber-optic equipment can pose dangers to personal safety. Ensure that anyone who works with this StorageTek equipment understands these dangers and follows safety procedures. Ensure that the optical ports of every laser transceiver module are terminated with an optical connector, a dust plug, or a cover.

Each fiber-optic interface in this StorageTek Fibre Channel equipment contains a laser transceiver that is a Class 1 Laser Product. Each laser transceiver has an output of less than 70 μ W and a wavelength of 850 nm. StorageTek's Class 1 Laser Products comply with EN60825-1(+A-11) and with sections 21 CFR 1040.10 and 1040.11 of the Food and Drug Administration (FDA) regulations.

The following translations are for users in Finland and Sweden who wish to identify laser safety and classification:

CLASS 1 LASER
LUOKAN 1 LASERLAITE
KLASSE 1 LASER APPARAT

■ Laser Product Label

In accordance with safety regulations, a label on each StorageTek Fibre Channel product identifies the laser class of the product and the place and date of the manufacturer. The label appears on top of a Fibre Channel tape drive and near the Fibre Channel connectors on a Fibre Channel tape library. A copy of the label is shown here:

CLASS 1 LASER PRODUCT
LASER KLASSE 1
APPAREIL A LASER DE CLASSE 1
COMPLIES WITH 21 CFR 1040.10 AND 1040.11

■ Fiber-Optic Cable Handling

Observe these precautions when you handle fiber-optic cables:

- Do not coil the cable to less than 96 mm (3.75 in.) in diameter.
- Do not bend the cable to less than 12 mm (0.5 in.) in radius. StorageTek recommends that a cable's bend radius be no less than 20 times the diameter of the cable.
- Do not pull on the cables; carefully place them into position.
- Do not grasp the cables with pliers, grippers, or side cutters; do not attach pulling devices to the cables or connectors.
- Keep cables away from sharp edges or sharp protrusions that could cut or wear through the cable; make sure that cutouts in the equipment have protective edging.
- Protect the cable from extreme temperature conditions.

WARNING:

Eye hazard. Never look directly into a fiber-optic cable, a fiber-optic connector, or a laser transceiver module. Hazardous conditions might exist from laser power levels that are capable of causing injury to the eye.

Be especially careful when using optical instruments with this equipment. Such instruments might increase the likelihood of eye injury.

- Install the connector's protective cover whenever the connector is not connected.

■ Fiber-Optic Cable Installation

Follow these guidelines when you install fiber-optic cables:

1. Cable routing:

- **Raised floor:** You may install fiber-optic cables under a raised floor. Route them away from any obstruction, such as existing cables or other equipment.

- **Cable tray or raceway:** Place the cables in position; do not pull them through the cable tray. Route the cables away from sharp corners, ceiling hangers, pipes, and construction activity.
- **Vertical rise length:** Leave the cables on the shipping spool, and lower them from above; do not pull the cables up from below. Use proper cable ties to secure the cable.
- **General:** Do not install fiber-optic cables on top of smoke detectors.

2. Cable management:

- Leave at least 4.6 m (15 ft) of cable at each end for future growth.
- Use strain reliefs to prevent the weight of the cable from damaging the connector.
- Review all information in this manual and in any related manuals about safely handling fiber-optic cables.

3. Connector protection:

- Insert connectors carefully to prevent damage to the connector or fiber.
- Leave the connector's protective cover in place until you are ready to make connections.
- Replace the connector's protective cover when the connector is disconnected.
- Clean the connector before making a connection. Make sure that there are no obstructions and that keyways are aligned.

■ Rack Safety and Precautions

WARNING:

Possible personal injury:

- **More than one person might be required to install equipment into the library's rack or to remove equipment from the library's rack.**
- **Personnel should take adequate precautions when they are moving a library that contains rack-installed equipment. The weight of some rack equipment might alter the height of the library's center of gravity. This condition might cause the library to tip during a move.**

Observe the following safety and handling precautions when you are installing equipment into the library's rack:

CAUTION:

Potential equipment damage: Do not exceed the maximum allowable weight (136 kg [300 lb]) and U-height (17U) for equipment in the rack area of this library.

- Ensure that the equipment has UL listing (listing by Underwriters' Laboratories), CSA certification (certification by the Canadian Standards Association), and CE compliance (compliance with the European Council's directives and standards).
- Understand that the library does not supply power to the rack area. So ensure that the rack-installed equipment has an adequate power source.

Note: If you remove power from the library by using the library's power switch, the rack-installed equipment will remain powered-on.

- Follow the manufacturer's guidelines to position, to support, and to fasten the equipment in the rack.
- Locate the equipment so that it does not block or hinder any ventilation openings in the library's rack area. For example, do not block library or drive exhaust areas, the electronic module exhaust area, perforated metal, or other similar ventilation.
- Locate the equipment so that the library doors adequately clear the equipment when you close them.
- Install the equipment from the bottom of the rack to the top of the rack; StorageTek recommends that you place the heaviest items near the bottom of the rack.
- Ensure that any equipment that you install within the rack is adequately cooled. The library's internal ambient temperature should not exceed the recommended operating temperature. Base cooling considerations upon the power dissipation within the rack space as well as upon the ambient room conditions that are external to the library. You must provide cooling for moderate power dissipation within the rack space.
- Ensure that the equipment in the rack does not create an overcurrent condition, whether equipment is connected directly to the branch circuit or to a power distribution strip.
- Ensure that the equipment in the rack has reliable earth ground, whether equipment is connected directly to the branch circuit or to a power distribution strip.

CAUTION:

Potential equipment damage: Do not exceed the maximum allowable weight (136 kg [300 lb]) and U-height (17U) for equipment in the rack area of this library.

Observe the following safety and handling precautions when you are installing equipment into the library's rack:

- Ensure that the equipment has UL listing (listing by Underwriters' Laboratories), CSA certification (certification by the Canadian Standards Association), and CE compliance (compliance with the European Council's directives and standards).
- Understand that the library does not supply power to the rack area. So ensure that the rack-mounted equipment has an adequate power source.
Note: If you remove power from the library by using the library's power switch, the rack-mounted equipment will remain powered on.
- Follow the manufacturer's guidelines to position, to support, and to fasten the equipment in the rack.
- Locate the equipment so that it does not block or hinder any ventilation openings in the library's rack area. For example, do not block library or drive exhaust areas, the electronic module exhaust area, perforated metal, or other similar ventilation.
- Locate the equipment so that the library's doors adequately clear the equipment when you close them.
- Install the equipment from the bottom of the rack to the top of the rack; StorageTek recommends that you place the heaviest items near the bottom of the rack.
- Ensure that any equipment that you place within the rack is adequately cooled. The library's internal ambient temperature should not exceed the recommended operating temperature. Base cooling considerations upon the power dissipation within the rack space as well as upon the ambient room conditions that are external to the library. You must provide cooling for moderate power dissipation within the rack space.
- Ensure that the equipment in the rack does not create an overcurrent condition, whether equipment is connected directly to the branch circuit or to a power distribution strip.
- Ensure that the equipment in the rack has reliable earth ground, whether equipment is connected directly to the branch circuit or to a power distribution strip

■ Electrostatic Discharge Damage Prevention

Before you touch any internal components in the library, including drives, you must take precautions against electrostatic discharge (ESD).

CAUTION:

Components are sensitive to static electricity: Even a small electrostatic discharge can damage an electrical component that is inside the library. A damaged component might not fail immediately, but over time, it will become worse and might eventually cause an “intermittent” problem. Be sure that you touch an *unpainted* metal surface of the library before you reach inside the library or touch the drives or optional interface equipment.

Before you touch any internal components:

1. With your finger, touch an *unpainted* metal surface of the library. In some libraries, you can touch the library’s frame. In other libraries, you might have to touch a bolt on the wall or on the door frame.
2. Keep your body movement to a minimum as you touch the drives or the library components.

Antistatic wrist straps that have clip-on ends are commercially available.

This chapter describes the hardware components of the library, the cell locations for cartridge tapes, and the two library operating modes (automatic and manual). For software information and drive information, refer to the publications that pertain to these specific topics.

The library is a robotic system that mounts cartridges into a storage cell or into a drive for read/write operations. It also moves cartridges from the cartridge access port (CAP) to storage cell or from cell to cell. [Figure 1-1 on page 1-2](#) through [Figure 1-4 on page 1-8](#) show the major components of the library, described in the following pages.

■ Tape Library Components

The tape library has four major components:

- A robot, which mounts and dismounts cartridges
- Storage cells for 156 to 678 cartridges
- A CAP that holds up to 20 cartridges in four magazines, with an optional second CAP that holds the same number of cartridges
- Drives, which perform read/write operations

Figure 1-1. Library Major External Components (C65081)

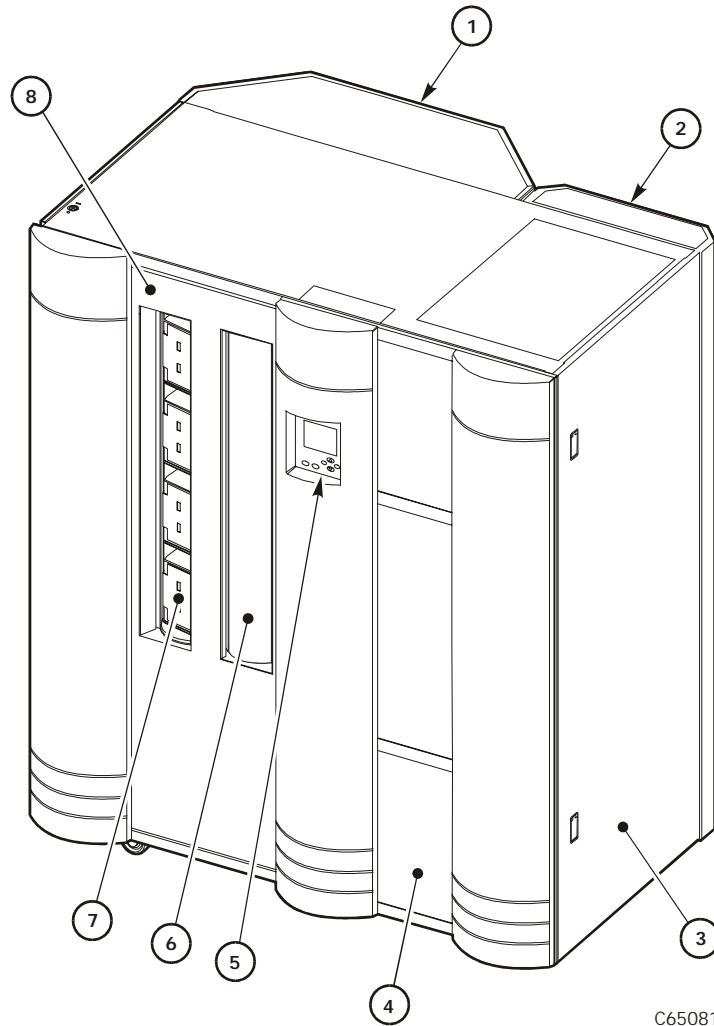

C65081

1. Expansion frame
2. Rear door
3. Drive access door
4. Right door
5. Operator panel
6. Optional CAP B (shown closed)
7. Standard CAP A (shown open)
8. Left access door

Robot

The robot moves cartridges between storage cells, between cells and tape drives, and between the CAP and cells. The robot consists of the Z column assembly (vertical motion), the theta mechanism (lateral motion), and the hand-camera assembly. [Figure 1-2 on page 1-4](#) shows these robot components.

The Z column assembly contains a Z column and Z carriage. The Z column attaches to the floor and ceiling of the tape library. The Z column can rotate almost 360 degrees to enable access to all the cells in the tape library.

The hand-camera assembly, which is attached to the Z carriage, grasps and releases cartridges. The Z carriage moves the hand up and down the Z column to storage cells, drives, or the CAP.

The camera, which is on the hand, is active only during a library audit. An audit occurs when you:

- Power-on the tape library.
- Open and close the left access library door.
- Make a request at the customer server console to audit the tape library.

During an audit, the camera reads the location and volume serial number (VOLSER) of each cartridge in the storage cells and reserved cells. Since this information is stored in the library's memory, the library does not rely on the camera to read cartridge locations or VOLSERS during mount and dismount operations.

The storage of audit data within the library has two implications for operation:

- Each time an audit occurs, you must use the system console to request a host update. This procedure adds the library audit information to the host memory.
- If you manually exchange a cartridge from a drive for one in storage, the host memory will continue to apply the VOLSER and location information from the first cartridge to the second cartridge. This might cause an error.

Figure 1-2. Robot Components (C65114)

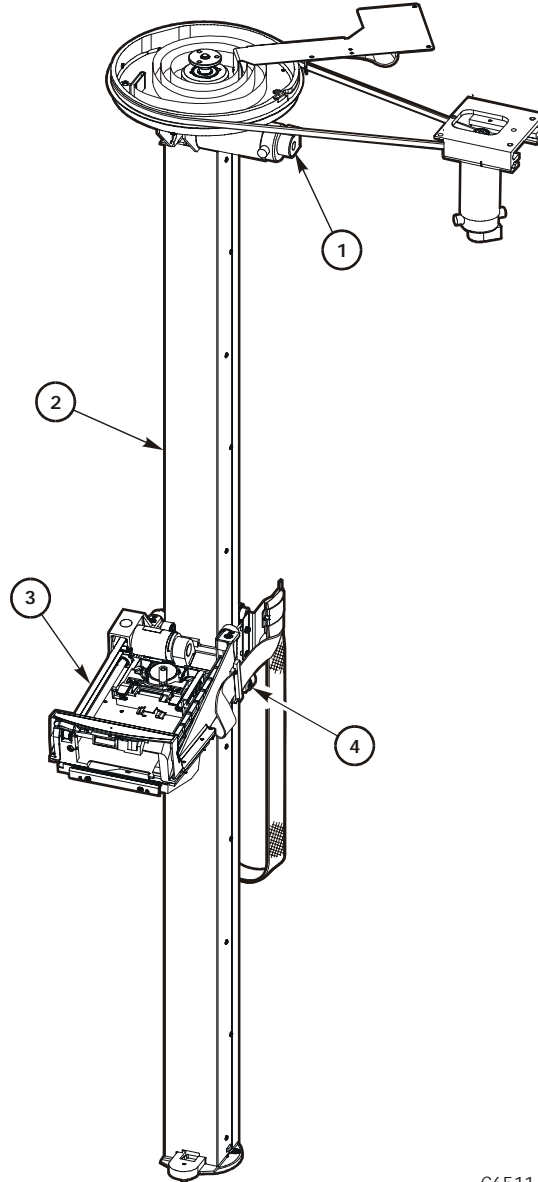

C65114

1. Z motor
2. Z column
3. Hand-camera assembly
4. Z carriage

Storage Cells

Host software locates cartridges by panel, column, row, and cell. The library contains storage cells for 156 to 678 cartridges, excluding the CAP cells. The number of cells is determined by how many drives are installed and whether the tape library has the standard rear window panel or the expansion frame. The expansion frame provides additional storage cells for 294 cartridges.

Cell Locations

Cartridges are stored in cell arrays that hold six cartridges. Cell arrays are stacked in columns and these columns are arranged in a circle around the robot assembly. Columns can hold up to 42 cartridges.

[Table 1-1 on page 1-6](#) lists tape library storage capacities. [Figure 1-3 on page 1-7](#) through [Figure 1-4 on page 1-8](#) show cell locations for the L700e tape library in its various configurations.

Note: The following statements apply to cell locations:

1. The library uses array targets for robotic calibration during an Initial Program Load (IPL).
2. Never put data cartridges in the reserved cells (refer to [“Reserved Cells” on page 1-9](#) for more information). If you do not want to store diagnostic and/or cleaning tapes in these cells, you must leave them empty.
3. The library does *not* use the drive and CAP locations to store cartridges.
4. The robot uses the swap cell (the top-most cell in the reserved area) for in-transit cartridges, to place a cartridge that is left in the hand-camera assembly when a power failure occurs, or to perform a swap operation.

Library Capacity

[Table 1-1 on page 1-6](#) lists the library storage capacities. Although library capacity is automatically configured when you bring the library online, check the operator panel to be sure that the capacity information is accurate.

Table 1-1. Tape Library Capacity

Expansion Frame	Second Drive Column	Drives Installed (Maximum)	Panel 2 Access	Total Data Cartridge Cells¹	Reserved Cells²
Yes (Full)	No	10 DLT/Ultrium or 6 9840/T9840B/T9940 + 1 DLT or 1 Ultrium	Entire	678	12
	Yes	20 DLT/Ultrium or 12 9840/T9840B/9940 + 2 DLT, or 2 Ultrium	Entire	618	12
No (2/3)	No	10 DLT/Ultrium or 6 9840/T9840B/T9940 + 1 DLT or 1 Ultrium	Entire	384	12
	Yes	20 DLT/Ultrium or 12 9840/T9840B/T9940 + 2 DLT or 2 Ultrium	Entire	324	12
No (1/3)	No	10 DLT/Ultrium or 6 9840/T9840B/T9940 + 1 DLT or 1 Ultrium	Partial	216	12
	Yes	20 DLT/Ultrium or 12 9840/T9840B/T9940 + 2 DLT or 2 Ultrium	Partial	156	12

Notes: ¹ These numbers do not include cells in the CAP or the reserved area.

² The reserved cells are composed of one swap cell and 11 cleaning and/or diagnostic cartridge slots. They are shown in [Figure 1-5 on page 1-10](#).

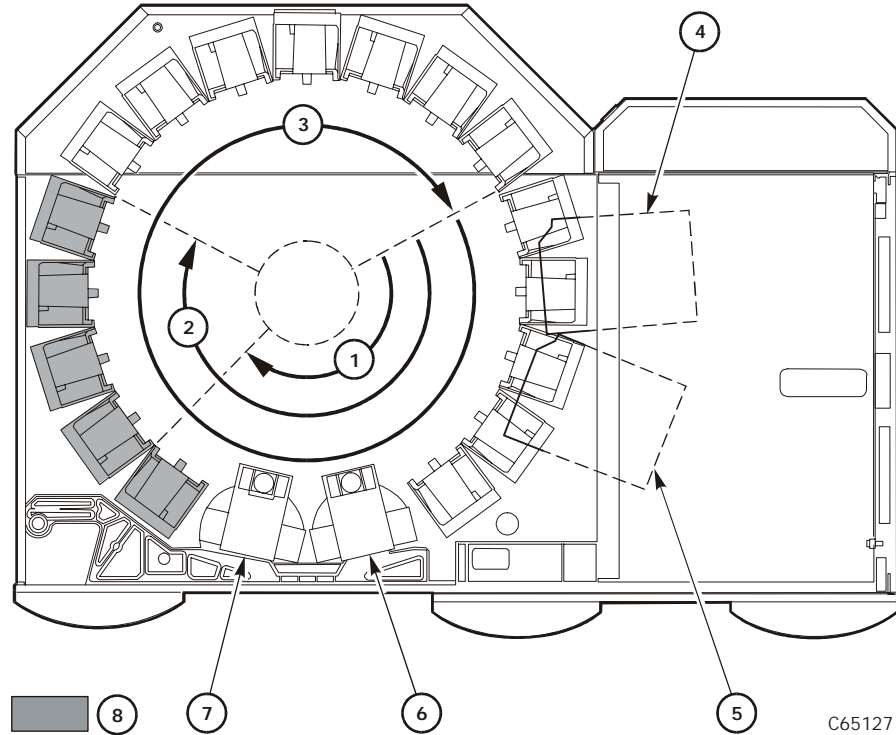
Figure 1-3. Locating Cartridges—Top View (C65127)

1. 1/3 capacity (partial access to Panel 2)
2. 2/3 capacity (entire access to Panel 2)
3. Full capacity (with optional expansion frame)
4. Drive column 0
5. Drive column 1 (optional)
6. CAP B (optional)
7. CAP A
8. Panel 2

Figure 1-4. Locating Cartridges—Panels, Cells, Rows (C65091)

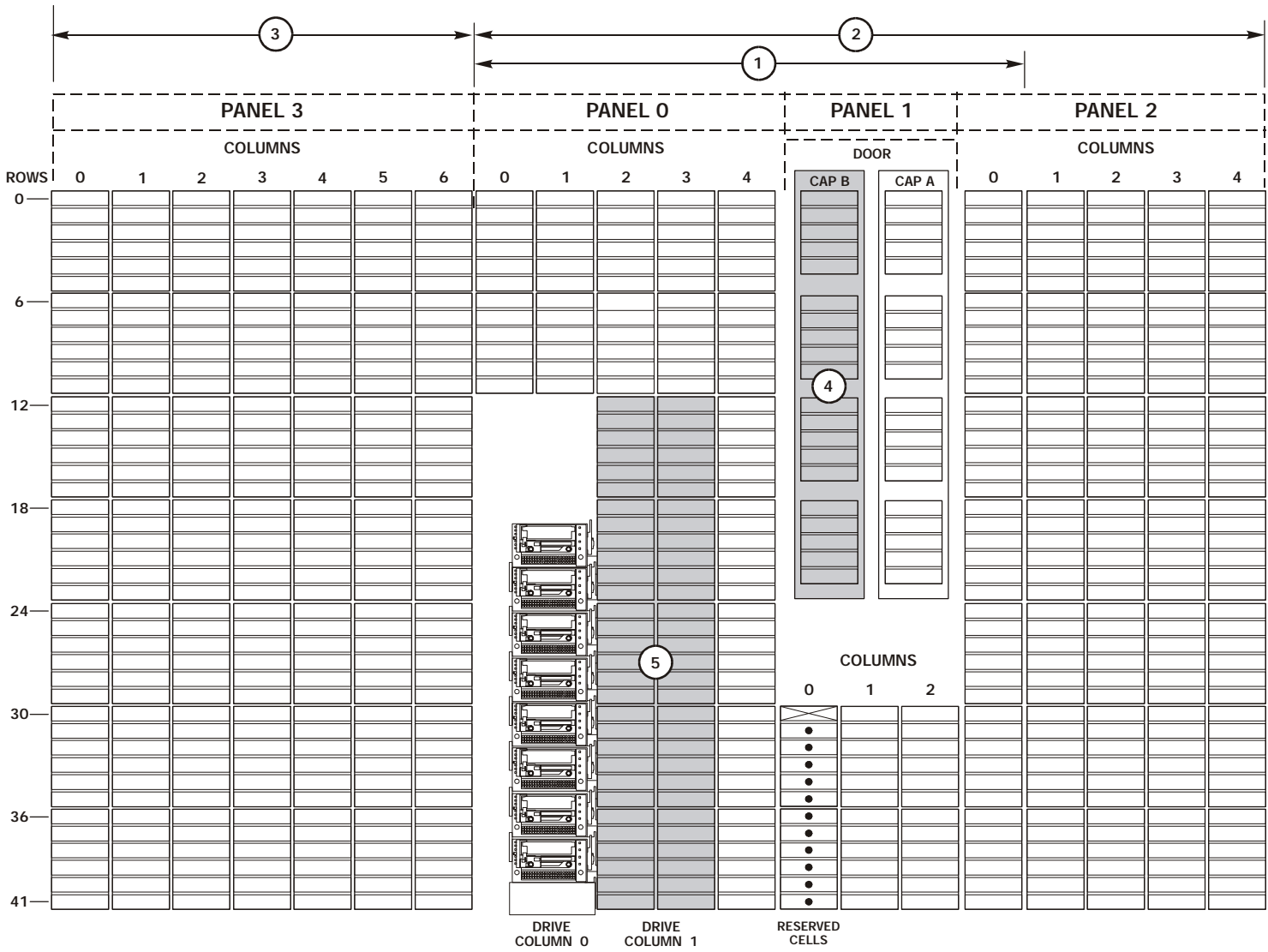

C65091

Figure 1-4. Locating Cartridges—Panels, Cells, Rows (Continued) (C65091)

-
1. 216-cartridge-cell configuration
 2. 384-cartridge-cell configuration
 3. Expansion frame (See note)

Note: 678-cartridge-cell configuration equals 384-cartridge-cell configuration plus Expansion frame.

4. Optional second CAP (See note)
5. Optional second drive column

Note: The optional second CAP replaces the front window. The optional second drive column replaces the 60 shaded cells.

Reserved Cells

[Figure 1-5 on page 1-10](#) shows the cells reserved for swapping cartridges and for diagnostic and cleaning cartridges. The top cell is the swap cell, which is reserved for in-transit cartridges. Do *not* place any cartridges into this cell. You may place any type of cleaning or diagnostic cartridges into the other 11 cells.

Note: Loading cleaning cartridges into any of these 11 cells enables Auto Clean upon the next IPL.

CAUTION:

System degradation: Do not insert data cartridges into these reserved cells. The host software will not find these cartridges.

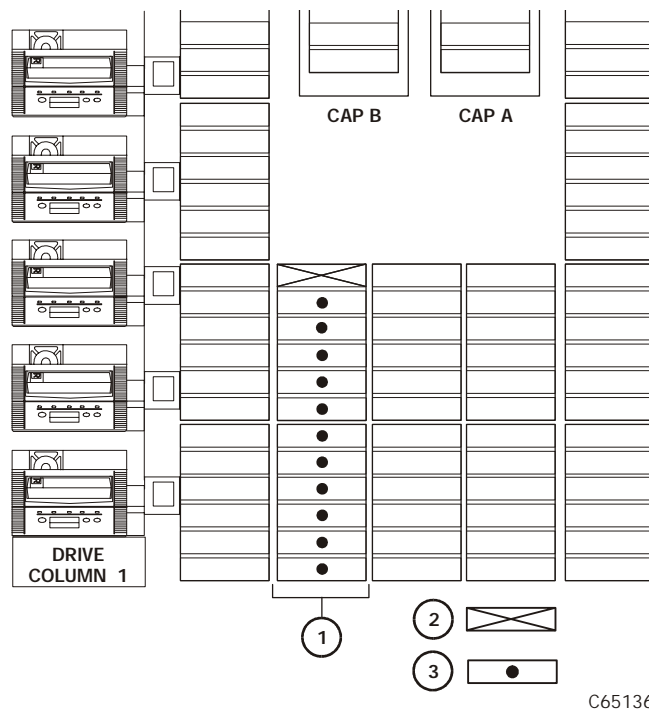
Figure 1-5. Reserved Cell Locations (C65136)

1. Location of reserved cells
2. Swap cell (leave empty)
3. Diagnostic and cleaning cartridges

Cartridge Access Port

A cartridge access port (CAP) is the location where you add cartridges to or remove cartridges from a library without interrupting normal cartridge mounts and dismounts by the robot. The library may have an optional, second CAP. Both CAPs are located on the right front door.

The CAP magazine is designed for easy loading. You can access the magazine by simply pulling down on the magazine handle and adding cartridges. Or, you can remove the magazine by lifting it out, load the cells, and place the magazine back into the CAP. Snap-on cartridge retention covers allow you to keep cartridges in place when transporting magazines.

For detailed procedures, refer to [“Importing Data Cartridges through the CAP”](#) and [“ ”](#) in Chapter 4, “Library Operation.”

Drives

The library can contain the following drive types:

- Digital Linear Tape (DLT) 8000 or DLT 7000E
- 9840/T9840B¹/T9940
- IBM Ultrium
- Hewlett Packard Ultrium
- Seagate Ultrium

CAUTION:

Possible data loss: StorageTek does not advise mixing DLT 7000 and DLT 8000 drives in the same library. If a DLT 7000 cartridge is inserted into a DLT 8000 drive, the tape can be read and written in 7000 mode.

If a DLT 8000 cartridge is inserted into a DLT 7000 drive, the drive will indicate “Medium Error/Calibration Error (03/8000)” if a read command is issued and, as with most tape drives, will write over any data present on the tape if a write command is issued at load point.

The maximum number of DLT or Ultrium drives is 20. The maximum number of 9840/T9840B/T9940 drives is 12.

As an operator, you might have to:

- Configure a drive in a library; refer to “[Drive Entries \(SCSI Drives Only\)](#)” on [page 3-10](#).
- Check drive status information; refer to “[Drive Status](#)” on [page 4-3](#).
- Manually mount a cartridge to a drive or dismount a cartridge from a drive; refer to “[Loading/Unloading Cartridges Manually](#)” on [page 4-28](#).

Note: During typical operation (or automated mode), the library’s robotic hand-camera assembly automatically places a cartridge into the drive or removes a cartridge from the drive when a command is sent from the host software.

For specific drive information, refer to your drive publications.

-
1. 9840 drive operator panel buttons are yellow ; T9840B drive buttons are purple.

■ **Horizon L Series Library Monitor Feature**

The optional Horizon L Series Library Monitor feature incorporates a web interface to the library. In addition to the feature, you will need a personal computer attached to the library's Ethernet port. The feature enables you to:

- “View” the library interior and visually check the status of tapes, drives, and CAP
- Initiate diagnostic tests on the library from the personal computer
- Make configuration changes or additions

Consult the compact disk which accompanies this feature for more information.

■ **Tape Library Safety Features**

Safety features are incorporated into the tape library. If the left access door is opened, an electrical interlock removes power from the robot assembly.

Behind the right front door, covers are placed over the logic card, the AC power supply, and the DC power supply to prevent you from coming into contact with hazardous voltages and sensitive electronics.

■ **Controlling Software**

Controlling software, within the client/server, requests tape read and write operations to the drives and robotic move operations for the tape library robotic components. Software determines where the cartridge is located by tracking the VOLSER and cell location during audits, then allocates which drive receives the cartridge. For specific information, refer to your software publications.

When the control path is a direct attachment, the software resides within the client central processing unit (CPU). When the control path is an indirect attachment, the software is divided between the server and the client CPUs. For specific information, refer to your software publications.

■ **Library Operating Modes**

An operating mode is the manner in which a tape library and the controlling software (also referred to as the customer's server software) interact. A library can operate in either automated mode or manual mode.

Automated Mode

Automated mode is the normal operating mode of the tape library. The controlling software instructs the robot to move the cartridge among the storage cells, drives, and CAP without operator intervention. Your tasks may include:

- Monitoring the tape library operator display for messages
- Importing a cartridge through the CAP
- Exporting a cartridge through the CAP
- Replacing a cleaning cartridge

Refer to [Chapter 4, “Library Operation,”](#) for the procedures.

Manual Mode

Manual mode occurs when the tape library is offline. Your tasks may include:

- Opening the tape library doors
- Moving the robot
- Locating a cartridge
- Removing a cartridge from the hand
- Mounting a cartridge into a drive
- Dismounting a cartridge from a drive
- Returning the tape library to online status

Refer to [Chapter 4, “Library Operation,”](#) for the procedures.

■ Auto Clean Feature

Drives occasionally need to be cleaned to prevent read/write errors.

The Auto Clean feature is enabled when your tape library is initializing and detects cleaning cartridges in the reserved cells. When a drive requires cleaning while Auto Clean is enabled, the robot will receive a software message telling it to retrieve a cleaning cartridge and place it into the drive.

If Auto Clean is not enabled, you must manually import a cleaning cartridge for the drive that requires cleaning. The “Clean Drive” request appears on the operator panel’s display.

Refer to [“Cleaning Cartridge Warning Count” in Chapter 3, “Configuration,”](#) for more information and procedures.

■ 13U Rack Area

You may use the internal 13U (0.57 m [22.75 in.] x 0.48 m [19 in.]) rack area, located behind the right front door, for additional equipment. Refer to “[Rack Safety and Precautions](#)” on page xxiii for precautions you must follow before installing equipment in this area.

Power cable space is provided in the cutout area of the rear door.

CAUTION:

Heat within rack area: Cooling considerations should be made based upon the power dissipation within the rack space, as well as the external library room ambient conditions. Cooling must be provided for moderate power dissipation within the rack space. Additional cooling is available from StorageTek.

This chapter describes the functions of the library operator panel, the library power switch, and provides samples of displays you could see on the operator panel display. It also lists tasks you can perform through the use of the operator panel. Refer to drive publications for information about operating the drives.

■ Operator Panel

The operator panel, recessed into the library's rack door, contains buttons, indicators, and a graphic display. [Figure 2-1 on page 2-2](#) shows the panel and describes each item.

Use this panel to:

- Monitor current information about the CAPs, configuration, drives, doors, drive cleaning, hardware and software versions, personality, and library status
- Help resolve library problems

If an error occurs, the display shows a fault symptom code (FSC), which you can give to a service representative to help resolve problems. Write down the FSC as soon as it is displayed.

- Set library, network, and drive configurations
- Rotate the CAPs
- Replace drive cleaning cartridges and set cleaning cartridge warning count
- Run library and drive tests
- Reset (start an initial program load [IPL] on) the library

For specific task instructions, refer to [Chapter 3, "Configuration"](#) and [Chapter 4, "Library Operation."](#)

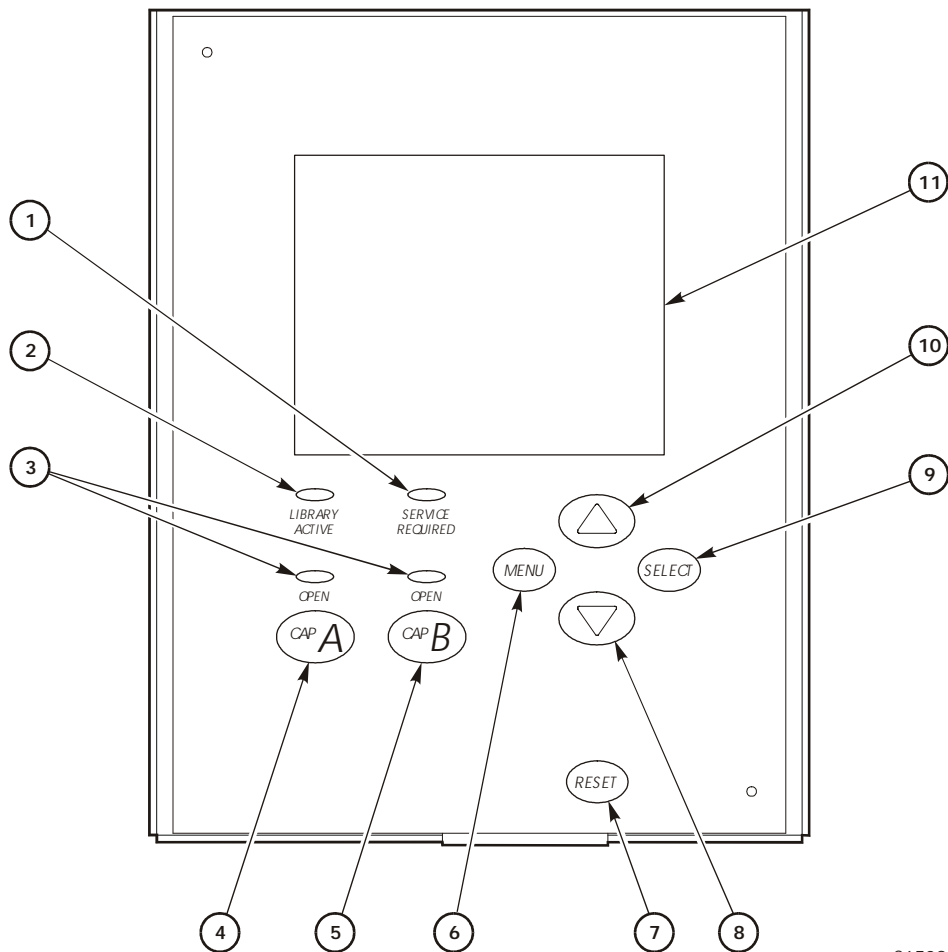
Figure 2-1. Operator Panel Display, Controls, and Indicators (C65083)

C65083

1. *Service Required* indicator is steadily red when human intervention is required.
2. *Library Active* indicator flashes green when the library is operational.
3. *Open* indicator is steadily amber when the CAP is open for you to import or remove cartridges.
4. CAP A open button rotates CAP A for you to access the magazines.
5. CAP B open button rotates CAP B for you to access the magazines.
6. **MENU** button initially places you into the Main Menu screen; subsequently, it returns you to a previously selected screen.
7. **RESET** button starts an IPL.
8. Arrow down button moves the cursor down the display screen or decrements an underscored value.
9. **SELECT** button selects an item on a menu; it also saves the currently underscored value and moves the cursor to the next field.
10. Arrow up button moves the cursor up the display screen; it also increments a value underscored on the screen.
11. Graphic display screen shows current information, FSCs, and allows input from menus.

Indicators

Three indicators provide basic status information: *Library Active*, *Service Required*, and *Open*. Refer to [Figure 2-1 on page 2-2](#) for details about these indicators.

Note: When the *Service Required* indicator is on, StorageTek recommends that you contact your service provider.

Buttons

Six buttons are provided on the operator panel: CAP, RESET, MENU, SELECT, and the up and down arrows. The CAP and RESET buttons let you directly manipulate the library; the remaining four buttons let you manipulate the menus and underscored values on the graphic display. Refer to [Figure 2-1 on page 2-2](#) for the location and a description of each button.

Note: The up arrow, down arrow, MENU and SELECT buttons manipulate only values that are under operator control. As you scroll down or up a list of selections, the cursor underscores these values. (You cannot manipulate values that do not permit underscoring.)

Display Screens

Screens on the graphic display show current information and allow your input. Information includes:

- Drive status
- CAP and CAP magazine status
- Library status
- Library capacity
- Library personality
- Library features
- Hardware and software versions
- SCSI type (single-ended or differential)
- Cleaning cartridge and Auto Clean status
- Ethernet ID
- Error and FSC information

Except for CAP status and error or FSC information, these values are set through an automatic configuration process that occurs during an IPL.

Values requiring your input are:

- Cleaning cartridge warning count
- SCSI drive configuration:
 - SCSI ID
 - Bus status (on or off bus)
- Network configuration:
 - Library name
 - IP address
 - Subnet mask
 - Library gateway
- Library configuration information:
 - SCSI ID
 - Fast Load enable/disable
 - Date/time
- Display screen brightness and contrast

You can also use the menus to run diagnostic tests.

The following pages describe the library's primary menus. For instructions on working with specific configuration values, see [“Operator Panel Entry” in Chapter 3, “Configuration.”](#)

Library Status

The “Library Status” screen is an information-only screen. It is the first screen to appear on the operator panel after an IPL.

STK L700e (Code Version 2.20)	Library type and firmware version
CAP Closed	CAP status
Library Online	Library status
No Remote Users	Number of users logged onto the the library through a remote interface
Column 0	The status of each drive in the drive column

Figure 2-2 shows an example Library Status screen. (For a list of drive status messages, see “Drive Status” on page 4-3.)

Figure 2-2. Library Initial Status Screen

```
STK L700e (CODE VER 2.20.00)
CAP CLOSED

LIBRARY ONLINE
NO REMOTE USERS
    COLUMN 0
00 BUSY
01 BUSY
02 LOADING
03 LOADING
04 EMPTY
05 EMPTY
06 EMPTY
07 ---
08 ---
09 ---
```

By pressing the MENU button from the Library Status screen, you can display the main menu (see Figure 2-3 on page 2-5).

Figure 2-3. Main Menu Screen

```
MAIN MENU :

FSC LOGS
CAP CONTENTS
DRIVE INFO
CLEANING INFO
DIAGNOSTICS
VERSION INFO
CONFIGURATION
```

FSC (Fault Symptom Code) Logs

The FSC Logs screen displays the last 20 fault symptom codes (FSCs), the number of occurrences, and the date and time of the last occurrence. The screen may be scrolled (if required) to view all FSCs. For more information, [“Reviewing FSC Logs” on page 4-17](#).

Note: Events listed in the log might not be failures. All events are recorded. FSCs are generated for both library and drive errors.

Figure 2-4. FSC Log Screen

3329	03	NONE
03/01/2004		14:46:14
3304	09	NONE
03/01/2004		14:46:14
30BB	02	NONE
03/01/2004		14:44:01
30BA	02	NONE
03/01/2004		14:44:01
30B9	02	NONE
02/28/2004		09:22:23
30B8	02	NONE
02/28/2004		08:27:14
4487	02	NONE
02/27/2004		16:52:33
3329	03	NONE

CAP Contents

The CAP Contents screen is an information-only screen. It displays either the VOLSER of a cartridge or status message for each slot in a CAP magazine. The CAP status screen is shown in [Figure 2-5](#).

Note: You must scroll down to view the contents of both CAPs.

Figure 2-5. CAP Status Screen

```
CAP A CONTENTS

MAGAZINE 1 CONTENTS
200042
57QF43R
EMPTY
EMPTY
EMPTY
MAGAZINE 2 CONTENTS
EMPTY
EMPTY
EMPTY
EMPTY
EMPTY
```

Drive Information

The Drive Information Menu is an information-only screen that lists manufacturing and status information about the selected drive (see [Figure 2-6](#)):

Vendor	The manufacturer of the drive
Type	The drive model
Status	The drive's local number and status (see "Drive Status" on page 4-3 for a list of status messages)
Serial Number	The serial number assigned by the drive's manufacturer
Interface Type	The type of client-to-drive interface (this example shows a SCSI interface, but a drive with Fibre Channel capability would display FIBRE I/F)
Code Version	The firmware version of the drive

See ["Drive Information" in Chapter 4, "Library Operation"](#) for instructions on how to access a drive.

Figure 2-6. Drive Information Menu

```
DRIVE INFORMATION MENU:
```

```
VENDOR: QUANT  
TYPE: DLT7000  
STATUS: 00 EMPTY
```

```
SERIAL NUMBER:  
XXXXXXXXXX
```

```
INTERFACE TYPE:  
SCSI I/F
```

```
CODE VERSION  
50
```

Cleaning Information

The Cleaning Info menu provides information about and control of the library's cleaning cartridges. It enables you to change the warning count for each type of cleaning cartridge. [Figure 2-7 on page 2-10](#) shows an example of the Cleaning Info menu:

Num Clean Cartridges	The total number of cleaning cartridges mounted in the reserved cells within the library
DLT Warn Count	The number times you want the DLT cleaning cartridge to be used before the library exports it through the CAP
9840/T9840B Warn Count	The number times you want the 9840/T9840B cleaning cartridge to be used before the library exports it through the CAP
9940 Warn Count	The number times you want the 9940 cleaning cartridge to be used before the library exports it through the CAP
HP LTO Warn Count IBM LTO Warn Count SGT LTO Warn Count	The number of times you want the Ultrium cleaning cartridge to be used before the library exports it through the CAP
Export Clean Cartridges	A procedure for moving cleaning cartridges from from the reserved cells to the CAP
Import Cartridges	A procedure for moving cleaning cartridges from the CAP to the reserved cells
Clean Cartridge Info	A path to an information screen that lists all cleaning cartridges in the library

The Cleaning Info menu lets you change the warning count for each type of cleaning cartridge and import/exporting cleaning cartridges. It also lets you check the number of times a cleaning cartridge has been used. For procedures, see [“Library Operation” in Chapter 4, “Library Operation.”](#)

Figure 2-7. Cleaning Information Menu

```
CLEANING INFO

NUM CLEAN CARTRIDGES: 00

DLT WARN COUNT: 000
9840 WARN COUNT: 000
9940 WARN COUNT: 000
HP LTO WARN COUNT: 000
IBM LTO WARN COUNT: 000
SGT LTO WARN COUNT: 000

EXPORT CARTRIDGES
IMPORT CARTRIDGES

CLEAN CARTIDGE INFO
```

Diagnostic Tests

Note: All Diagnostic tests except for Clean Drive require the tape library and associated drive to be offline.

The Main Diagnostics Menu (see [Figure 2-8](#)) lets you perform the following tests:

- **Drive-related tests:**
 - **Clean Drive.** Enables you to clean tape drives.
 - **Mount.** Loads test tapes to a drive.
 - **Dismount.** Unloads test tapes from a drive.
 - **Mount-Dismount Loop.** Loads and unloads test tapes from a drive. You may designate the number of times the tape library goes through the loop.
 - **Run Drive Check.** Determines that the drive is in working order.
- **Note:** StorageTek does not recommend looping tests excessively.
- **Get-Put Loop.** Gets a diagnostic tape and returns it to the same location. You may designate the number of times the tape library goes through the loop.
- **Demo Mode.** Simulates tape library operation.

For more information, see [“Running Diagnostic Tests”](#) on page 4-18.

Figure 2-8. Main Diagnostics Menu

```
MAIN DIAGNOSTICS MENU:  
  
DRIVE DIAGNOSTICS  
GET/PUT LOOP  
DEMO MODE
```

Version Information

The Version Info Menu is an information-only screen (see example in [Figure 2-9](#)). It displays the version level of the library's functional code, the date the code was completed, and the serial number of the logic card (also referred to as "the MPC card").

Figure 2-9. Version Information Menu

```
VERSION INFO MENU:  
  
CODE VERSION:  
  2.20.00  
  
CODE BUILT ON:  
  OCT 22 2000  16:38:19  
  
HARDWARE / VERSION  
  MPC 00000098
```

Main Configuration Menu

The Main Configuration Menu (see [Figure 2-10](#)) allows you access to the configuration menus (library, drive, network) and to the panel display controls. You can access screens that let you view the library personality, perform a feature upgrade, and input a password for a Web interface product.

Figure 2-10. Main Configuration Menu

MAIN CONFIGURATION MENU

LIBRARY CONFIG

DRIVE CONFIG

NETWORK CONFIG

PERSONALITY MODULE

WEB PASSWORD

DISPLAY INFO

Library Configuration

The Lib Config Menu displays library capacity information and lets you modify the library's configuration.

The screen displays:

Lib SCSI I/F ID (or Lib Fibre I/F ID)	Library interface identifier
Fast Load	Fast Load feature status (on or off)
Date	Current date
Time	Current time
Auto Clean	Is Auto Clean is enabled
CAPs	Number of CAPs installed
User Cells	Number of data storage cells in the library
Drive Column	Number of drive columns installed
Expansion Frame	Is an expansion frame installed

[Figure 2-11](#) shows an example library configuration screen. From this menu, you may access editing menus for these library settings. See [“Library Entries” on page 3-4](#) for procedures and additional information.

Figure 2-11. Library Configuration Menu

```
LIB CONFIG MENU:  
LIB SCSI I/F ID: 00  
FAST LOAD: OFF  
DATE: 03/01/2001  
TIME: 23:59  
AUTO CLEAN: OFF  
CAPS: 2  
USER CELLS: 336  
DRIVE COLUMN: 2
```

Library SCSI Interface Configuration

The Lib SCSI I/F Config Menu lets you view the library's SCSI type (differential or single-ended) and access an edit menu for the library's SCSI ID. [Figure 2-12](#) shows an example of this menu.

Figure 2-12. Library SCSI Interface Configuration Menu

```
LIB SCSI I/F CONFIG MENU:  
SCSI TYPE: DIFFERENTIAL  
LIB SCSI I/F ID: 00
```

Library Fibre Channel Interface Configuration

The Lib Fibre I/F Config Menu lets you view the library's worldwide ID and Port 0 worldwide ID. It also lets you access an edit menu for the library's Port 0 address. [Figure 2-13](#) shows an example of this menu.

Figure 2-13. Library Fibre Channel Interface Configuration Menu

```
LIB FIBRE I/F CONFIG MENU:

LIBRARY WORLDWIDE ID:
00.00.00.00.00.00.00.00

PORT 0 WORLDWIDE ID:
00.00.00.00.00.00.00.00

PORT 0 CONFIGURATION
```

Drive Configuration

The drive configuration menu lets you modify each drive's configuration. [Figure 2-14](#) shows an example screen. For each drive, the menu displays:

- Drive position
- Drive type
- If the drive path is SCSI, the drive's SCSI ID and its SCSI bus relationship with the library.
- If the drive path is Fibre Channel, the menu displays FIBRE I/F after the drive type.

Sub-menus let you change the SCSI ID and configure whether the drive is on the same SCSI bus as the library.

For more information, see [“Drive Entries \(SCSI Drives Only\)” on page 3-10.](#)

Notes: These statements apply to this menu:

1. The cursor position is saved on all screens that list the library's drives.
2. The panel displays 16 lines of data per menu. If your library contains more than eight drives, you must use the down arrow button to scroll to drives 08 and above.

Figure 2-14. Drive Configuration Menu

```
00 DLT7000_ID:01
    ON BUS: OFF
01 _FIBRE I/F
02 DLT7000_ID:03
    ON BUS: OFF
03 IBM_LTO_ID:04
    ON BUS: OFF
04 SGT_LTO_ID:05
    ON BUS: OFF
05 9840_FIBRE I/F

06 HP_LTO_ID:06
    ON BUS: OFF
07 9840_FIBRE I/F

08 DLT7000_ID:07
```

Network Configuration

The Network Config Menu (see [Figure 2-15](#)) lets you modify the library's network configuration and view the library's Ethernet (web interface) address. (At the time of publication, you cannot change the DHCP status.) For procedures, see [“Network Entries” on page 3-12](#).

Figure 2-15. Network Configuration Menu

```
NETWORK CONFIG MENU:
LIBRARY NAME:
-

IP ADDRESS:
 000.000.000.000
NETWORK GATEWAY:
 NOT SET
SUBNET MASK:
 000.000.000.000

DHCP: DISABLED

ETHERNET ADDRESS:
```

Personality Module

The Personality Module Menu lets you view the library's personality (vendor) setting. This feature must be installed by the service representative. The screen below illustrates how you may check the Personality Module.

Figure 2-16. Personality Module Information

```
PERSONALITY MODULE INFO:  
  
STATUS:  
  PRESENT  
TYPE:  
  NORMAL  
VENDOR:  
  0  
LIBRARY VENDOR ID:  
  0  
LIBRARY VENDOR NAME:  
  STK  
  
LIBRARY PRODUCT TYPE:  
  L700e
```

Display Information

The Display Info Menu (see [Figure 2-17](#)) leads to menus that let you adjust the contrast and backlight on the graphic display screen. For more information, see ["Screen Characteristics" on page 3-15](#).

Figure 2-17. Display Information Menu

```
DISPLAY INFO MENU:  
  
CONTRAST: 09  
  
  DEFAULT = 16  
  
BACKLIGHT: 128  
  
  DEFAULT = 128  
  
RESTORE DEFAULTS  
  
MENU TO EXIT
```

Operations Overview

Table 2-1 lists the tasks that you can perform through the operator panel menus. The right column refers you to another page in this manual for more information. The tasks appear in the order you would find them on the operator panel main menu:

- FSC Logs
- CAP Status
- Cleaning Info.
- Diagnostics
- Version Info.
- Configuration

Table 2-1. Operations Guide

Task	Page for Operator Panel Instructions
Understand CAP status messages	page 4-2
Understand library status messages	page 4-3
Understand drive status messages	page 4-3
Review FSC logs	page 4-17
Check CAP magazine	page 4-5
Manage cleaning cartridges	See list for individual tasks.
• Import cleaning cartridges through CAP	page 4-9
• Export cleaning cartridges to CAP	page 4-9
• Check usage count	page 4-5
• Check/set warning count	page 3-16
• Manually clean a drive	page 4-16
• Import data cartridges through CAP	page 4-11
• Export data cartridges through CAP	page 4-14
Run diagnostic tests	page 4-18
• Run get/put loop	page 4-19
• Operate in demo mode	page 4-20
• Run drive mount diagnostics	page 4-19
Check firmware version	page 2-11
Check library personality information	page 4-7
Set configuration	page 3-3
• Set library SCSI ID	page 3-4

Table 2-1. Operations Guide (Continued)

Task	Page for Operator Panel Instructions
• Set library Fibre Channel Port 0 address	page 3-5
• Enable/disable Fast Load	page 3-7
• Set date and time	page 3-8
• Set drive configuration	page 3-10
• Set network configuration	page 3-12
• Set screen characteristics	page 3-15

■ Library Power Switch

The library power switch is a circuit breaker or breakers behind the right front door of the library. [Figure 2-18 on page 2-19](#) shows the power switch location. This switch, attached to the AC power distribution unit (PDU), controls the AC power to the library and drive column.

The power switch has two configurations:

- A single breaker on the AC power distribution unit controls the library and a single drive column.
- An optional second breaker, located on the second power distribution unit, powers the second drive column and an optional second library power supply.

Notes: If your library has two circuit breakers:

1. The optional PDU must be connected to a separate electrical circuit.
2. If only one breaker is powered off, the second breaker will still be powered on.

To apply power to the library and drive column, lift the switch or switches.

To remove power from the library and drive column:

- Make sure all jobs are complete.
- Push down on the library power switch or switches.

Figure 2-18. Library Power Switch Location (C65117)

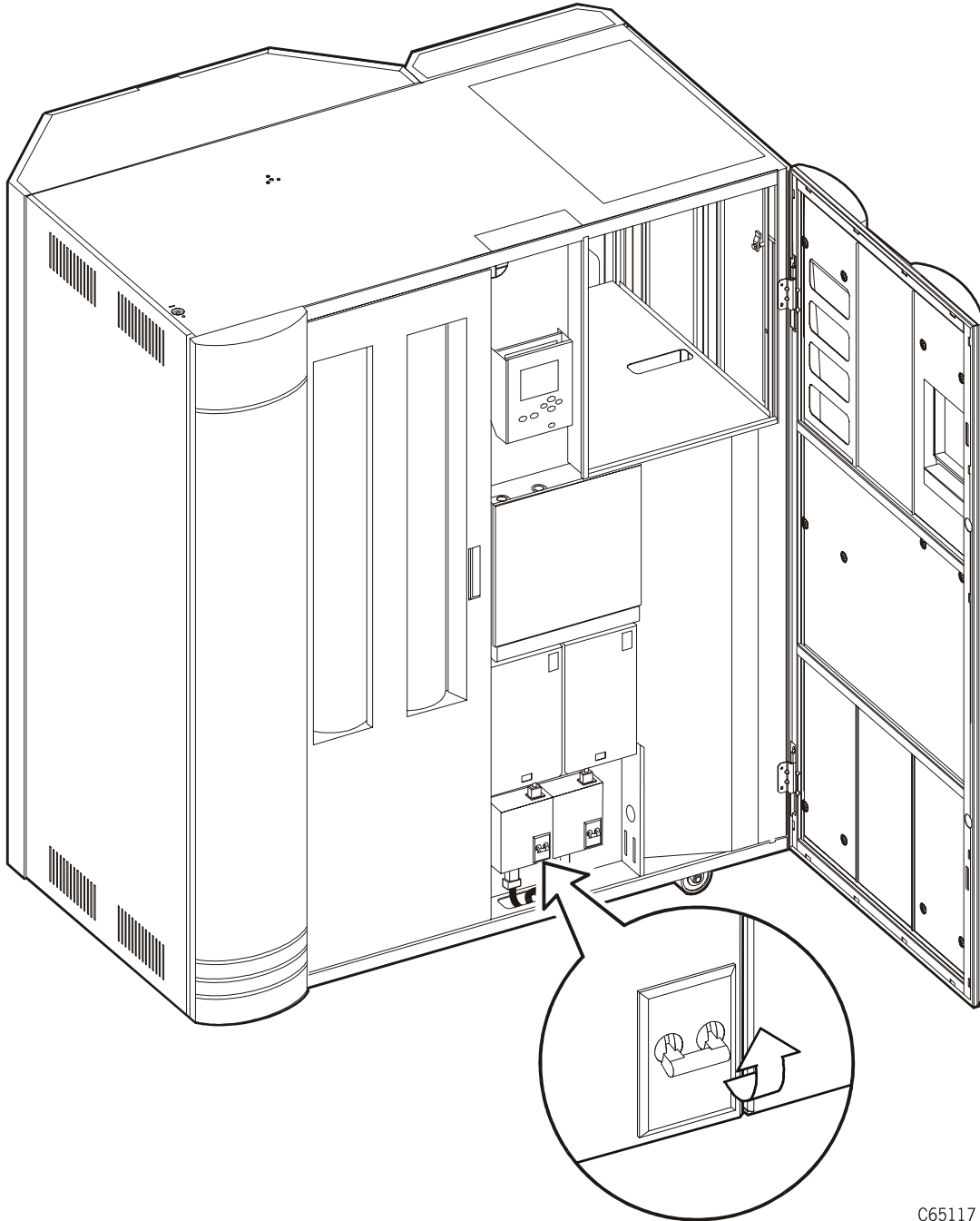

C65117

Redundant AC Power Option

The APC uninterruptible power supply (UPS) is an optional feature designed to prevent blackouts, brownouts, sags and surges in AC power. This UPS also filters out small fluctuations and disturbances in AC line voltage.

The UPS comes with a power strip that allows you to connect up to eight additional components to the UPS. If power fails, the UPS will supply power to the equipment connected to the power strip until the batteries are exhausted.

While running on battery power, periodic beeps will sound:

- Press the TEST/ALARM DISABLE button to turn off this alarm.
- A continuous beep will sound *two* minutes before the UPS will shutdown.

Notes:

- The UPS is maintained and serviced by APC representatives. Refer to the APC documentation for specific information about the UPS.
- The UPS requires additional cooling if installed in the library. This cooling fan is also an optional feature for the library.

■ Tape Drive Power Switches

The tape drives are behind the drive access door, inside the right side door of the library. Each drive has a power switch that controls the power to only that drive.

Note: The library's main power switch controls the AC power to the library *and* the drive column.

To remove power from a drive, push the drive switch to the "O" position.

To supply power to a drive, push the drive switch to the "|" position

Figure 2-19. Drive Power Switch Locations (C65131)

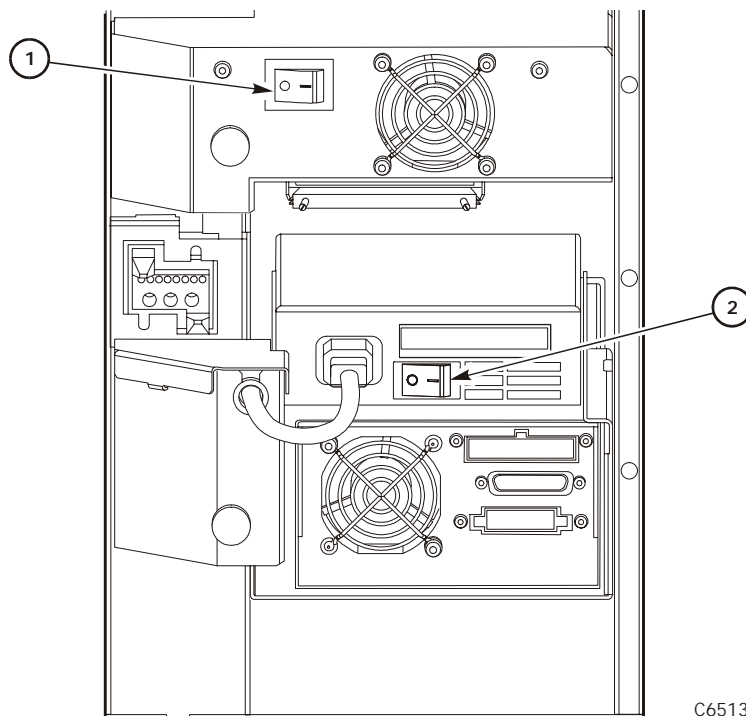

C65131

1. DLT or Ultrium drive power switch
2. 9840/T9840B/T9940 drive power switch

This page intentionally left blank.

This chapter describes how to configure the library and drives for operation. Configuration requires you to:

1. Enable Auto Clean (if desired) by installing cleaning cartridges
2. Power on or reset the library
3. Enter library and drive configuration information
4. Place the library online (if necessary)
5. Send a client command to load library audit information into client memory

After power-on, the library automatically verifies and loads some configuration values, such as drive locations, Auto Clean status, capacity, and drive types. Before the library is fully operational, however, someone must enter the remaining configuration values.

Typically, your service representative will configure your library during installation, during firmware upgrade, or after drives are added. If you must change the library's configuration, you may enter the values through the operator panel.

Note: You may need to consult with your systems administrator for some information.

■ Enabling Auto Clean

You will need to clean the drives occasionally to prevent read and write errors. Enabling the Auto Clean feature allows the library to initiate drive cleaning without your intervention. (A drive is cleaned with a special cleaning cartridge.)

To enable Auto Clean, load valid cleaning cartridges into any of the 11 cells that are reserved for cleaning and diagnostic cartridges. For the locations of these cells, refer to [“Reserved Cells” in Chapter 1, “General Information.”](#)

Note: To be valid

- A cleaning cartridge must have “CLN” in its VOLSER label.
- 9840/T9840B cleaning cartridges must also have a “U” on their media ID labels.
- T9940 cleaning cartridges must have a “W” ID label.
- Ultrium cartridges have labels specific to the drive manufacturer. For more information, see [Appendix A, “Cartridge Tape Information.”](#)

The Auto Clean feature is automatically enabled if you load even one cleaning cartridge into the reserved cell area and then reset the library.

For instructions on how to use the CAP to insert cleaning cartridges, see [“Importing Cleaning Cartridges through the CAP” on page 4-9](#). For the location of the reserved cells, see [“Reserved Cells” on page 1-9](#)

To install cleaning cartridges in the reserved cells:

1. Unlock and open the front doors (see [“Opening the Library Front Doors” in Chapter 4, “Library Operation”](#))
2. Verify that the cleaning cartridges are right side up (the VOLSER numbers should be closest to the top edge and facing outward).

CAUTION:

Potential static electricity damage to electrical components. Take precautions against electrostatic discharge by touching gray, unpainted metal (such as the library’s frame) before reaching into the library. Avoid touching any electrical component.

Confined space: While reaching inside the library, take care to avoid bumping your head or catching your clothes on protruding edges.

3. Place a cartridge into any of the 11 designated cells.
4. Close and lock the front access door.

Note: You may follow this same procedure to load diagnostic cartridges into the reserved cells. (Every diagnostic cartridge has “DG” as the first two letters of its VOLSER.) However, loading diagnostic cartridges alone does not enable Auto Clean.

■ Powering on the Library

Powering on the library supplies power to the library electronics and to the drive column. If you have a second drive column, you must power on both supplies. Powering on also initiates an IPL of the library.

To power on the library, lift the switch (circuit breaker) or switches behind the right front door of the library. If you are not familiar with the location of the switches, refer to [Figure 2-18 on page 2-19](#).

Note: If the tape library does not power on, contact your service provider. If you have a StorageTek maintenance agreement, you may contact StorageTek’s Customer Support Services and report the problem.

■ Initializing and IPLing the Library

Powering on the library causes it to initialize components and perform an IPL (initial program load). During initialization, the library prepares the robot for operation and audits any cartridges in the storage and reserved cells. During an IPL, the library loads the operating code and automatically verifies some configuration values, such as drive locations and drive types.

You will have to re-IPL (reset) the library when you:

- Are directed to do so by your system administrator or a StorageTek Central Support Services engineer
- Must change the library configuration (for example, when you have to change the library's SCSI ID)

Re-initializing the Library

You will have to re-initialize the library in the rare instance when a robotic component malfunctions. Before re-initializing the library, perform any necessary manual operation tasks (see [“Operating in Manual Mode” on page 4-22](#)).

To re-initialize the library, make sure that all drives are powered on and perform one of these actions:

- Power off and power on the library (also causes an IPL)
- Open and close the front door

Re-IPLing the Library

You will have to re-IPL (reset) the library when:

- You are directed to do so by your system administrator or a service representative
- You have to change the library configuration (for example, when you have to change the library's SCSI ID)

To re-IPL the library after it is already powered on, make sure that all the drives are powered on and press the RESET button on the operator panel.

■ Entering Configuration Data

After the IPL is complete, the status screen will appear on the operator panel. At this point, you must make choices about your library, drives, and network and enter those choices into the library's memory.

Note: You may need to consult with your systems administrator for some information.

You may enter all configuration data through the operator panel. See [“Operator Panel Entry”](#) (in the following section) for specific instructions. If you have installed the Horizon L Series Library Monitor, you also can enter some configuration data through a workstation or a PC that is running a Netscape or Microsoft browser. For more information, access the online help files for the Horizon L Series Library Monitor.

Operator Panel Entry

Entering configuration data through the operator panel prepares the library for operation. For a detailed description of the operator panel, see [“Operator Panel” on page 2-1](#).

Library Entries

Four entries are required for a library—other entries will vary with your options:

- Library SCSI ID or Fibre Channel Port 0 address
- Drive Fast Load enable/disable
- Date
- Time

Note: The procedures below assume that you will make all entries during one, operator panel entry session. Each item is saved as it is changed, *except* for the library’s SCSI ID or Fibre Channel Port 0 address: to save a revised library SCSI ID, you must reset the library by pressing the RESET button.

Setting the Library’s SCSI ID

If the control path for the library is SCSI, you must enter the library’s SCSI ID at the operator panel. Set the library SCSI ID from the Lib SCSI I/F Config Menu.

Note: The information below explains special circumstances for selecting a SCSI ID (address) for the library:

1. When configuring the library to a Unix-based workstation, StorageTek recommends that you use a dedicated SCSI client host bus adapter (HBA):
 - For wide SCSI adapters, you may assign any address from 0 to 14 for the library.
 - For narrow SCSI adapters, the range of addresses is 0 to 6.
2. If you choose to use the embedded system bus on the SPARC station, select address 6, 5, 2, or 0 for the library; the remaining targets are reserved for Sun peripherals.
3. For IBM RISC System/6000 machines, available addresses on the embedded system bus are 6, 5, 3, and 2.

4. If you use Automated Cartridge System Library Software (ACSL), its level must be Version 5.3.2 or higher

To set the library's SCSI ID:

1. From the online status screen, press the MENU button.

The Main Menu will display.

2. Press the down arrow button until the cursor underscores CONFIGURATION.

3. Press the SELECT button.

The Main Configuration Menu will appear and the cursor will line up with LIBRARY CONFIG.

4. Press the SELECT button.

The Lib Config Menu will appear and the cursor will line up with LIB SCSI I/F CONFIG.

5. Press the SELECT button.

The Lib SCSI I/F Config Menu will appear. (This menu also displays the type of SCSI interface: differential or single-ended.)

6. Press the arrow buttons until the cursor underscores SCSI ID.

7. Press the SELECT button.

The Set Lib SCSI ID Menu will appear.

8. Press the up and down arrow buttons to select the correct ID.

9. Press the SELECT button to save the changes. (You may press the MENU button to abort.)

10. If the library SCSI ID is the only configuration value you wish to set at this time, press the RESET button. If you wish to set other configuration values before you reset the library, continue with the next section.

Setting the Library Fibre Channel Port 0 Address

If the control path for the library is Fibre Channel, you must set the Library's Fibre Channel Port 0 address. The library Fibre Channel Port 0 address locates the library's Port 0 on the Fibre Channel loop. Set the library Fibre Channel Port 0 address from the Lib Fibre I/F Config Menu.

Note: Before you enter a Port 0 address, you must first set the library's Fibre Channel hard address option to *enabled*.

If you configure the library for soft addressing, you are allowing the network's software to configure the Port 0 address. For this addressing approach, you must set the Fibre Channel hard address option to *disabled*.

The default for the hard address option is *disabled*.

Consult with the system administrator before selecting the library's Port 0 addressing option.

Set the library Fibre Channel Port 0 address from the Lib Fibre I/F Config Menu.

To set the library Fibre Channel Port 0 address:

1. From the online status screen, press the MENU button.

The Main Menu will display.

2. Press the down arrow button until the cursor underscores CONFIGURATION.

3. Press the SELECT button.

The Main Configuration Menu will appear and the cursor will line up with LIBRARY CONFIG.

4. Press the SELECT button.

The Lib Config Menu will appear and the cursor will line up with LIB FIBRE I/F CONFIG.

5. Press the SELECT button.

The Lib Fibre I/F Config Menu will appear and the cursor will line up with PORT 0 CONFIGURATION. This menu also displays the library's worldwide ID (the node ID) and the Port 0 worldwide ID (the port ID). These two IDs are set at the factory and cannot be changed. Each ID is 64 bits and uses the IEEE registered format.

6. Press the SELECT button.

The Fibre Port 0 Configuration menu will appear.

If you want to allow the network's software set the library Port 0 address, set the hard address option to DISABLED by:

- a. Pressing the arrow buttons until the cursor underscores AUTO ADDRESS.
- b. Pressing the SELECT button. The Port Hard Address Edit Menu.
- c. Pressing the up and down arrow buttons to select DISABLED.
- d. Pressing the SELECT button to save the selected option.

Note: The default for the hard address option is DISABLED.

If you want to set the library Port 0 address, you must set the `HARD ADDRESS` option to `ENABLED`, enter a port address by:

- a. Selecting `ADDRESS` from the Fibre Port 0 Configuration menu. The Port Address menu will display.
 - b. Pressing the up and down arrow buttons to select a digit for each field in the three-field address. Permissible addresses are 001 through 125.
 - c. Pressing the `SELECT` button to save the address.
7. If the library Fibre Channel Port 0 address is the only configuration value you wish to set at this time, press the `RESET` button. If you wish to set other configuration values before you reset the library, continue with the next section.

Reviewing Port 0 Worldwide ID

When a library has a Fibre Channel interface, the Port 0 worldwide ID identifies the library's Port 0 (that is, the lower MPU card) on the Fibre Channel system.

The ID is automatically displayed when you access the Fibre Channel Interface Configuration Menu. It cannot be changed.

Reviewing Library Worldwide ID

When a library has a Fibre Channel interface, the library's worldwide ID identifies the library as a node on the Fibre Channel system. The ID is automatically displayed when you access the Fibre Channel Interface Configuration Menu. It cannot be changed.

Enabling/Disabling Fast Load

These two terms are defined as follows:

Fast load on: The robot will mount a tape to a drive and then immediately report the move completed.

Fast load off: The robot will mount a tape to a drive and wait at the drive location until the tape is completely loaded before reporting the move completed.

Note: Some host software does not support the fast load enabled option.

Enable or disable the Fast Load feature from the Lib Config Menu. To set either feature:

1. At the Lib Config Menu screen, press the arrow button until the cursor underscores `FAST LOAD`.
2. Press the `SELECT` button.

An editing screen appears.

3. Press the up and down arrow buttons to select either ON or OFF.
4. Press the SELECT button to save the changes. (You may press the MENU button to abort.)
5. If you have already changed the library's SCSI ID or Port 0 address and are planning to exit the Main Configuration Menu at this time, you must press the RESET button. If you want to set other configuration values, continue with the next section.

If you have not changed the library's SCSI ID or Port 0 address and are not setting other configuration values, press the MENU button until you exit all menus.

Setting the Date

Set the date and time from the Lib Config Menu:

1. At the Lib Config Menu screen, press the arrow button until the cursor underscores DATE.
2. Press the SELECT button.
An editing screen appears.
3. On the editing screen:
 - a. Press the up and down arrow buttons to select a value for each portion (field) of the date.
 - b. Press the SELECT button to move right to the next field.
 - c. Press the MENU button to move left to the previous field.
4. When the screen displays your desired setting, press the SELECT button from the right-most field to save the changes. You may press the MENU button from the left-most field to abort.
5. If you have already changed the library's SCSI ID or Port 0 address and are planning to exit the Main Configuration Menu at this time, you must press the RESET button. If you wish to set other configuration values, continue with the next section.
6. If you have not changed the library's SCSI ID or Port 0 address and are not setting other configuration values, press the MENU button until you exit all menus.

Setting the Time

Set the time from the Lib Config Menu. FSC log entries correspond to this time setting:

1. At the Lib Config Menu screen, press the arrow button until the cursor underscores `TIME`.
2. Press the `SELECT` button.
An editing screen appears.
3. On the editing screen:
 - a. Press the up and down arrows to select a value for each portion (field) of the time.
 - b. Press the `SELECT` button to move right to the next field.
 - c. Press the `MENU` button to move left to the previous field.
4. When the screen displays your desired setting, press the `SELECT` button from the right-most field to save the changes. (You may press the `MENU` button from the left-most field to abort.)
5. If you have already changed the library's SCSI ID or Port 0 address and are planning to exit the Main Configuration Menu at this time, you must press the `RESET` button. If you wish to set other configuration values, continue with the next section.
6. If you have not changed the library's SCSI ID or Port 0 address and are not setting other configuration values, press the `MENU` button until you exit all menus.

Configuring a Personality Module

If you are planning to use the Horizon L Series Library Monitor, you must install its personality module and other components according to the documentation included in the Horizon L Series Library Monitor shipping package. You should consult this documentation for instructions on setting required configuration data.

Setting the Web Password

If your library uses the Horizon L Series Library Monitor, you must set a Web password at the operator panel. For instructions on setting this value, see the documentation that shipped with the Horizon L Series Library Monitor.

Drive Entries (SCSI Drives Only)

Notes: For 9840/T9840B/T9940 drives only:

1. The drive's SCSI ID and bus status can be entered from the library's operator panel if the drive has firmware version 1.24 or higher. Check the drive's firmware version, by selecting `DRIVE INFO` from the Main Menu.
2. Configuring a 9840/T9840B/T9940 drive might involve more than setting the drive's SCSI ID and bus status. For more information about 9840/T9840B/T9940 drive configuration options and instructions, refer to the *9840/T9840B/T9940 Tape Drive Service Reference Manual*, PN 95740.

Two entries complete the configuration options for each SCSI drive:

- SCSI ID
- Bus status (on or off bus)

Note: "On Bus" means that the drive is on the same SCSI bus as the library. "Off Bus" means that the drive is *not* on the same SCSI bus as the library.

Set the drive SCSI IDs and bus status from the drive configuration menu. You can enter both values for each drive at the same time:

1. At the Main Configuration Menu, press an arrow button until the cursor underscores `DRIVE CONFIG`.
2. Press the `SELECT` button.

The screen will list all installed drives, and the cursor will align with the first drive on the list.

An example of the format is:

```
00 DLT7000 ID: __
           ON BUS: ON
```

The first two digits are the drive's logical number (the number that the library has assigned the drive). The tape library sets this number during its automatic configuration sequence (at power-on or reset). It is an internal number *only* and is shown for information *only*.

Note: The uppermost drive within the column is designated as "0," the next is "1," and so forth.

Next to the logical number is the drive type (DLT 7000 in this example). To the right of the drive type is the ID or SCSI address. On the next line is the drive's bus status.

Ultrium drives will display as:

- IBM LTO for IBM Ultrium drives
- SGT LTO for Seagate Ultrium drives
- HP LTO for Hewlett Packard Ultrium drives

Drive information might also appear on the menu as:

- FIBRE I/F if the drive is a Fibre Channel drive
- INVALID if the drive's SCSI ID is an invalid address

3. Press the arrow buttons to scroll to the drive you wish to change and press the SELECT button.

The Set Drive SCSI ID Menu will appear.

Note: The operator panel displays only 16 lines per menu. If the library contains more than eight drives, you must use the down arrow button to scroll to drives 09 and above.

4. Press the up and down arrow buttons to change the ID.
5. Press SELECT to save your changes.

A message screen will appear to indicate that the library is saving the new ID. Then the drive configuration menu will reappear.

Notes: The new SCSI ID for a 9840/T9840B/T9940 drive might not appear right away.

6. Press the arrow down button to get to the drive's second line of information (the drive's bus status field).
7. Press the SELECT button.

The Set Drive SCSI Bus Menu will appear.

8. Press the up and down arrow buttons to change the bus status to ON or OFF.
9. Press the SELECT button to save the changes. (You may press the MENU button to abort.)

The drive configuration screen will reappear.

10. Continue these steps until all drives are configured.

Note: You cannot set any configuration data for Fibre Channel drives.

11. If you have already changed the library's SCSI ID or Port 0 address and are planning to exit the Main Configuration Menu at this time, you must press the RESET button. If you wish to set other configuration values, continue with the next section.

12. If you have not changed the library's SCSI ID or Port 0 address and are not setting other configuration values, press the MENU button until you exit all menus.

Network Entries

Use the Network Config Menu to configure the library for your network. Four entries set the library's network configuration:

- Library name
- IP address
- Network gateway
- Subnet mask

Note: You may need to consult with the systems administrator for some information.

You also may view the library's Ethernet address.

Viewing the Ethernet Address

This is a six-byte address, unique to each library. The address is written into the MPC card at the factory and cannot be changed. An example of an Ethernet address is 00:10:4f:00:05:01.

To view the Ethernet address:

1. At the Main Configuration Menu, press the arrow down button to line up the cursor with NETWORK CONFIG.
2. Press the SELECT button.

The Network Config Menu will appear and the library's Ethernet address appears at the bottom of the screen.

3. If you have already changed the library's SCSI ID or Port 0 address and are planning to exit the Main Configuration Menu at this time, you must press the RESET button. If you wish to set other configuration values, continue with the next section.

If you have not changed the library's SCSI ID or Port 0 address and are not setting other configuration values, press the MENU button until you exit all menus.

Setting the Library Name

The system administrator might assign the library a name. The name is mapped to the IP address but does not affect operation. To set the library name:

1. At the Network Config Menu, press an arrow button until the cursor underscores LIBRARY NAME.
2. Press the SELECT button. An editing screen appears.

3. On the editing screen:
 - a. Use the up and down arrow buttons to select a value for each character (field) in the name.
 - b. Use the SELECT button to move right to the next field.
 - c. Use the MENU button to move left to the previous field.

Note: Do not enter a library name longer than 30 characters.

4. When the screen displays your desired setting, press the SELECT button twice to save the changes. You may press the MENU button from the left-most field to abort.
5. If you have already changed the library's SCSI ID or Port 0 address and are planning to exit the Main Configuration Menu at this time, you must press the RESET button. If you wish to set other configuration values, continue with the next section.

If you have not changed the library's SCSI ID or Port 0 address and are not setting other configuration values, press the MENU button until you exit all menus.

Setting the IP Address

The system administrator might assign the library an IP address, which makes the library accessible through a network. This is a four-byte address that must be set with information obtained from the system administrator. The value set identifies the library and makes it accessible through a network.

An example of an IP address entry is 192.0.0.1

Note: To use the Horizon L Series Library Monitor, you must set the library's IP address at the operator panel.

To set the IP address:

1. At the Network Config Menu, press an arrow button until the cursor underscores LIBRARY NAME.
2. Press the SELECT button. An editing screen appears.
3. On the editing screen:
 - a. Use the up and down arrow buttons to select a value for each three-digit field in the address.

Note: Do *not* leave the first field equal to zero (000)

- b. Use the SELECT button to move right to the next field.
- c. Use the MENU button to move left to the previous field.

4. When the screen displays your desired setting, press the **SELECT** button from the right-most field to save the changes. You may press the **MENU** button from the left-most field to abort.
5. If you have already changed the library's SCSI ID or Port 0 address and are planning to exit the Main Configuration Menu at this time, you must press the **RESET** button. If you wish to set other configuration values, continue with the next section.

If you have not changed the library's SCSI ID or Port 0 address and are not setting other configuration values, press the **MENU** button until you exit all menus.

Setting the Network Gateway Address

A network gateway in a large network allows devices on one subnet to interface with devices on another subnet (see [“Setting the Subnet Mask Address” on page 3-15](#)). This four-byte address must be specified by the system administrator.

Note: Entering this address is optional. It sets up the gateway connection between subnets, but it is applicable only when such a connection exists and is necessary for library operation. Consult with your systems administrator for additional information.

To set the network gateway address:

1. At the Network Config Menu, press an arrow button until the cursor underscores `NETWORK GATEWAY`.
2. Press the **SELECT** button.
An editing screen appears.
3. On the editing screen:
 - a. Press the up and down arrow buttons to select a value for each three-digit field in the address.
 - b. Press the **SELECT** button to move right to the next field.
 - c. Press the **MENU** button to move left to the previous field.
4. Press the **SELECT** button from the right-most field to when the screen displays your desired setting to save the changes. (You may press the **MENU** button from the left-most field to abort.)
5. If you have already changed the library's SCSI ID or Port 0 address and are planning to exit the Main Configuration Menu at this time, you must press the **RESET** button. If you wish to set other configuration values, continue with the next section.

If you have not changed the library's SCSI ID or Port 0 address and are not setting other configuration values, press the MENU button until you exit all menus.

Setting the Subnet Mask Address

This is a four-byte notation (specified by the system administrator) to resolve routing within your intranet. This address makes the library accessible through a subnet on a large network. An example of a subnet mask entry is 255.255.254.0.

To set the subnet mask address:

1. At the Network Config Menu, press an arrow button until the cursor underscores SUBNET MASK.
2. Press the SELECT button. An editing screen appears.
3. On the editing screen:
 - a. Press the up and down arrow buttons to select a value for each three-digit field in the address.
 - b. Press the SELECT button to move right to the next field.
 - c. Press the MENU button to move left to the previous field.
4. Press the SELECT button from the right-most field when the screen displays your desired setting to save the changes. (You may press the MENU button from the left-most field to abort.)
5. If you have already changed the library's SCSI ID or Port 0 address and are planning to exit the Main Configuration Menu at this time, you must press the RESET button. If you wish to set other configuration values, continue with the next section.

If you have not changed the library's SCSI ID or Port 0 address and are not setting other configuration values, press the MENU button until you exit all menus.

Screen Characteristics

You also can change the operator panel's screen characteristics from the main configuration menu. The screen characteristics are saved in non-volatile memory.

To change the contrast and backlight (or brightness) of the operator panel screens:

1. At the main configuration menu, press an arrow button until the cursor underscores DISPLAY INFO.
2. Press the SELECT button. The display information menu will appear.

3. Press the arrow buttons to line up with the desired screen characteristic: CONTRAST or BACKLIGHT.

An editing screen will appear.

4. Press the up and down arrow buttons to change the count value.

Note: To reset the screen characteristics to the default values, line up the cursor with DEFAULT SCREEN CHARACTERISTICS and press the SELECT button.

5. Press the SELECT button to save the changes. (You may press the MENU button to abort.)
6. If you have already changed the library's SCSI ID and are planning to exit the Main Configuration Menu at this time, you must press the RESET button. If you try to exit the main configuration menu, a message will appear requesting that you reset the library.

If you have not changed the library's SCSI ID, you may exit the configuration menu to do other tasks.

Cleaning Cartridge Warning Count

After a predetermined count, a cleaning cartridge must be replaced and disposed of at the site.

If the Auto Clean feature is enabled, use the operator panel to set the maximum number of times a cleaning cartridge can be used (or the warning threshold).

Note: The Auto Clean feature is automatically enabled if you insert even one cleaning cartridge into the reserved cell area and then reset the library.

Check your tape drive's product manual for the recommended use and life of the drive's cleaning cartridge.

You set the cleaning cartridge warning count from the main menu screen. To set this number:

1. From the online status screen, press the MENU button. The main menu screen will appear.
2. Press the arrow button until the cursor lines up with CLEANING INFO.
3. Press the SELECT button.

The CLEANING INFO screen will appear. It displays the number of cleaning cartridges in the reserved area at initialization.

4. Press an arrow button until the cursor is at the appropriate drive's WARNING COUNT.
5. Press the SELECT button for your choice.

An editing screen will appear. The editing screen will display the current setting for the cartridge warning count. The maximum recommended warning count is shown below the current setting.

6. Press the arrow buttons to change the warning count.
7. Press the SELECT button to save the changes. (You may press the MENU button to abort.)
8. Press the MENU button to return to the library status screen.

Horizon L Series Library Monitor Entries (Optional)

The Horizon L Series Library Monitor is an optional Web-based interface to the library. If you ordered this interface for your library, your service representative should install it for you. Before you can use the Horizon L Series Library Monitor to monitor the library or alter the library's configuration, your service representative must enter two values at the operator panel:

- The library's IP address
- The library's Web password

For instructions on how best to make these entries, see the documentation included in the Horizon L Series Library Monitor shipping package. For instructions on using the interface to alter the library's configuration or monitor library activity, access the online help files for the Horizon L Series Library Monitor.

■ Loading Tapes into the Library

When you are ready to place the library into production, you may load data cartridges inside the library. The most efficient way to load a great quantity of tapes into the library is to manually load them into the cells.

CAUTION:

Confined space: While working within the library, take care to avoid bumping your head or catching your clothing on protruding edges.

Figure 3-1 and Figure 3-2 on page 3-19 illustrate how cartridges are placed into cells.

Figure 3-1. Placing Tapes into Array Cells—9840, T9840B and T9940 (C65298)

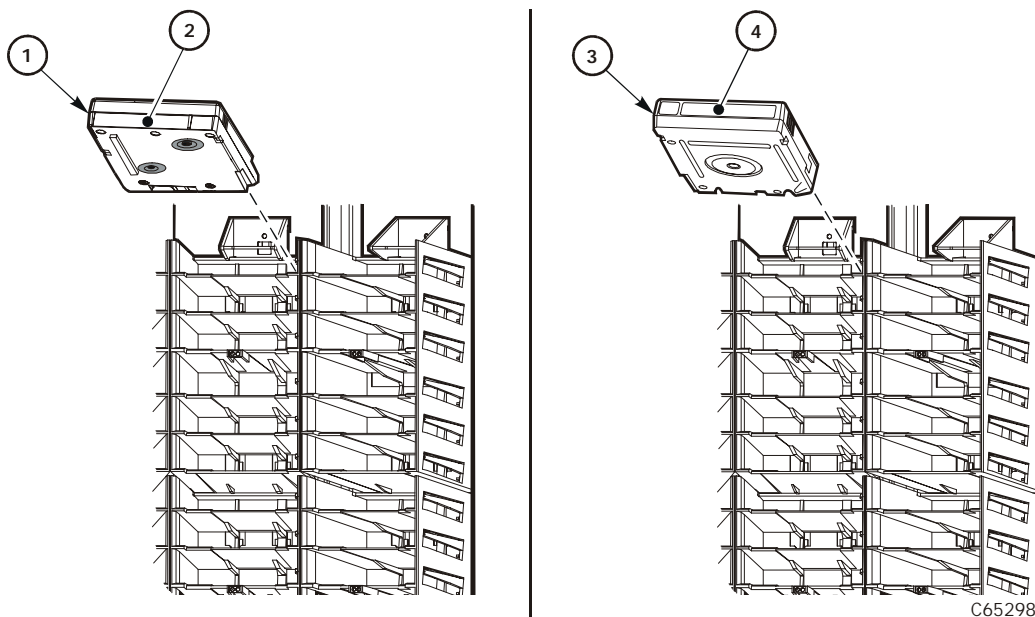

1. 9840/T9840B cartridge
2. 9840/T9840B cartridge label
3. T9940 cartridge
4. T9940 cartridge label

Note: Use only cartridges designed for your type of tape drives.

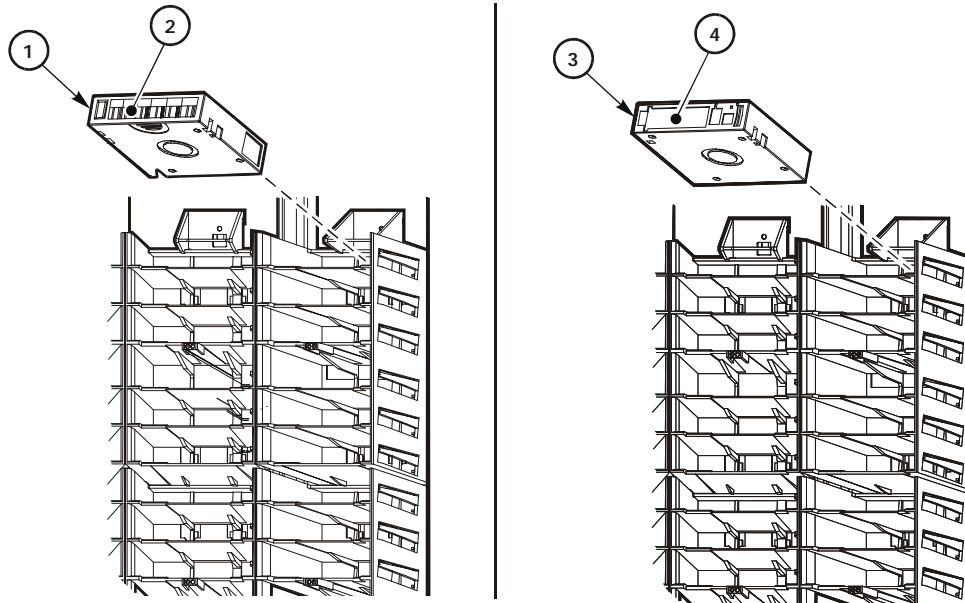
Figure 3-2. Placing Tapes into Array Cells—Ultrium, DLT, and SDLT (C65333)

C65333

1. Ultrium cartridge
2. Ultrium cartridge label
3. DLT and SDLT cartridge
4. DLT and SDLT cartridge label

You must first unlock and open the main access door. This procedure is explained in [“Opening the Library Front Doors”](#) on page 4-22.

You may also load cartridges into array cells by using the CAP(s). While this method is more time-consuming to fully populate the library, the procedure is explained in [“Importing Data Cartridges through the CAP”](#) on page 4-11.

After you have loaded all the cartridges, close and lock the main door. The robot will automatically audit the cartridges and their locations within the library.

■ **Placing the Library Online**

When you are ready to use the library for production, you must first:

- Enter the system command to place all drives online
- When all drives are online, enter the command to place the library online
- Enter the command to upload the library audit data to the client system memory (see the following paragraphs)

■ **Sending Library Audit Data to the Client**

During an initialization, the library audits the location and VOLSER of all cartridges in the storage and reserve cells. The library also performs an audit when:

- You power on the tape library.
- You open and close the front library door.
- You make a request at the server console to audit the tape library.

You must follow every audit with a client command that loads the library audit data (the catalog) into client memory. For instructions on how to send this command, refer to your software and system publications.

Library Operation

4

This chapter contains the procedures for operating the library in:

- Automated mode
- Manual mode

Note: When the client controls the library, refer to your software publications and enter the command at the console to perform the desired activity. For some activities, you might have to ask your systems administrator for the required information.

■ Operating in Automated Mode

Automated mode is the normal operating mode of the library. When the library is online and the robot is mounting and dismounting cartridges, monitor your operator console and the library operator panel for messages and respond appropriately.

When a tape library is online, you also might need to:

- Monitor the operator panel for status messages
- Export cleaning cartridges
- Import cleaning cartridges
- Import cartridges into the library through CAP
- Export cartridges from the tape library through the CAP
- Replace a cleaning cartridge
- Manually clean a drive
- Review the FSC log
- Run diagnostic tests

The following text describes how to perform these activities.

Monitoring Status Information

You can monitor CAP, library, remote user, and drive status information through the library status screen (see [Figure 4-1 on page 4-2](#)). This is the main screen on the operator panel. It displays after initialization is complete and also when you press the MENU button while viewing the Main Menu.

You also can monitor drive information, CAP magazine status, the cleaning cartridge usage count, and the library's "personality" information through operator panel menus.

Figure 4-1. Example Library Status Screen (C65329)

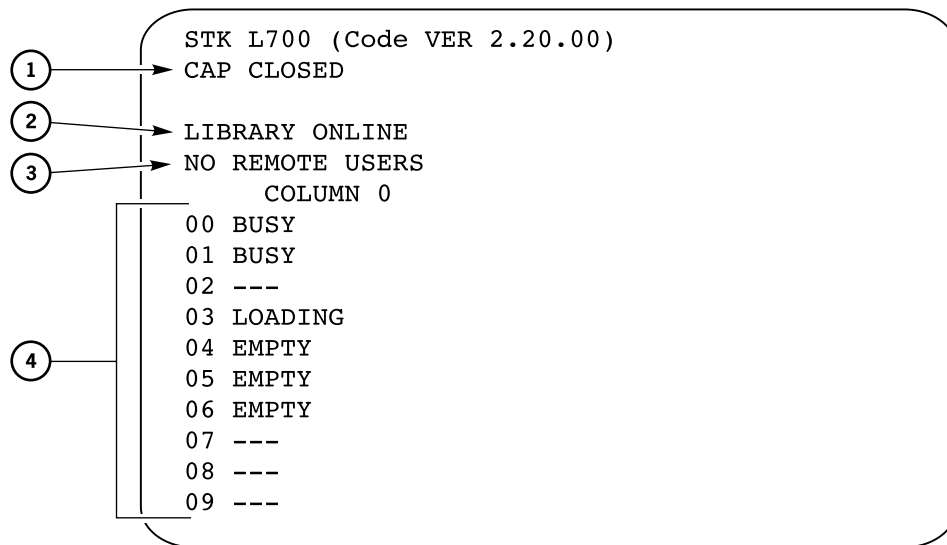

C65329

1. CAP status message
2. Library status message
3. Remote users status message
4. Drives status messages

CAP Status

The first line of status information on the library status screen indicates the condition of the CAP. [Table 4-1](#) explains the messages that might appear on this line.

Table 4-1. CAP Status Messages

Message	Explanation
OPEN	The CAP door is currently open. (The <i>Open</i> indicator also is on.) You may insert cartridges or remove the CAP magazines. But you cannot view the CAP magazine contents through the operator panel menus.
CLOSED	The CAP door is currently closed.
CLOSED(LOCKED)	The CAP door is currently closed and locked. Before you can open the CAP door, you must issue a command from your system console.
TRANSITION	The CAP door has stalled while attempting to open.
UNKNOWN	The library does not recognize the current state of the CAP door.

Library Status

The library status line indicates the current state of the library: [Table 4-2](#) explains the messages that might appear on this line.

Table 4-2. Library Status Messages

Message	Explanation
LIB MAIN DOOR OPEN	The library's front door is open. When you close it, the library will reset (initialize).
LIB INIT REQUIRED	The library requires initialization. You must press the RESET button.
LIBRARY NOT READY	The library is not available to perform operator-requested actions. Some status information might be available through the network interfaces.
LIBRARY READY	The library has completed initialization and is ready to perform requested actions.
LIB MAINTENANCE MODE	The library is offline because it is performing diagnostic tests.
INTERVENTION REQUIRED	The library is experiencing a problem. You should note the FSC (if the library has issued one) and call your service representative.
LIB UNKNOWN STATE	The library does not recognize its current state. You should note the FSC (if the library has issued one) and call your service representative.

Remote Users Status

Following the library status line is a message indicating the number of users who are currently accessing the library remotely. Currently, the status message on this line never changes.

Drive Status

[Table 4-3 on page 4-3](#) summarizes drive status messages that might appear on the library status screen:

Table 4-3. Drive Status Messages

Message	Explanation
INIT REQUIRED	You must initialize this drive.
NOT CONNECTED	This drive is not connected to a SCSI bus.
UNKNOWN DRIVE	The library does not recognize the type of drive in this location.

Table 4-3. Drive Status Messages (Continued)

Message	Explanation
NOT COMMUNICATE	This drive is not communicating with the client or the drive power is off.
NOT FUNCTIONAL	This drive is not operating properly.
NOT LOADABLE	The library cannot load a cartridge into this drive.
EMPTY	This drive does not have a tape loaded.
CARTRIDGE IN	The drive contains a cartridge, but the cartridge is not loaded into the drive.
CLEAN NEEDED	This drive requires cleaning.
CLEAN FAILED	The attempt to clean this drive failed.
LOADING	The library is mounting a cartridge to this drive.
REWOUND	The cartridge in this drive has been rewound.
UNLOADING	The library is dismounting a cartridge from this drive.
LOADED	The library has loaded a cartridge into this drive.
REWINDING	The cartridge in this drive is being rewound.
BUSY	This drive is performing a read or write operation.
CLEANING	The drive is being cleaned.

Note: The operator panel displays only 16 lines per screen. If the library contains more than eight drives, you must use the down arrow button to scroll to Drives 08 and above.

Drive Information

To view details about an installed drive, including its serial number and firmware version:

1. Press the MENU button to display the Main Menu.
2. If necessary, press an arrow button until the cursor lines up with DRIVE INFO.
3. Press the SELECT button.
A list of all installed drives will appear.
4. Use the arrow buttons until the cursor underscores the desired drive.
5. Press the SELECT button.

The Drive Information Menu will appear (see [Figure 2-6 on page 2-8](#)). The screen lists the manufacturer, model, status, serial number, interface type,

and firmware version of the selected drive. See [Table 4-3 on page 4-3](#) for a list of drive status messages.

CAP Magazine Status

To check the status of a CAP magazine and its contents:

1. Press the MENU button to display the Main Menu.
2. If necessary, press an arrow button until the cursor lines up with CAP STATUS.
3. Press the SELECT button.
A blank screen will appear.
4. Press the SELECT button again.

The CAP Contents menu will appear. The screen lists the VOLSER of each cartridge in an installed magazine or it lists a status message. See [Table 4-4](#) for the status messages that appear on this list.

Note: Each CAP has four magazines, numbered one through four, from the top location to the bottom.

Table 4-4. CAP Magazine Slot Status Messages

Message	Explanation
EMPTY	This magazine slot does not contain a cartridge.
UNKNOWN	This magazine slot contains a cartridge, but the library has not yet performed the necessary audit to identify the cartridge.
UNREADABLE	This magazine slot contains a cartridge, but the camera could not read the cartridge's VOLSER label.

CAP States

When exporting or importing cartridges through the CAPs, the following CAP states may be displayed:

Table 4-5. CAP States

State	Explanation
CAP A (B) Open	Specified CAP is open for exporting or importing of cartridges
CAP A (B) Closed	Specified CAP is closed and locked

Table 4-5. CAP States (Continued)

State	Explanation
CAP A (B) Transition	Specified CAP is stalled during an open or close transition. This message indicates a problem and an error is posted to the FSC log.
CAP A (B) Unknown	The specified CAP is in an unknown state. Consult the FSC logs.

Cleaning Cartridge Usage Count

This procedure assumes that you have loaded cleaning cartridges into the reserved cells and have subsequently reset the library. (Taking these steps enables the Auto Clean function.) You then can check the usage count of cleaning cartridges in the reserved cells or in both the reserved cells and the CAP.

Cartridges in the Reserved Cells

To check the number of times that the cleaning cartridges have been used since they were loaded into the reserved cells in the library:

1. Press the MENU button to return to the Main Menu.
2. Press the arrow buttons until the cursor underscores CLEANING INFORMATION.
3. Press the SELECT button.

The panel displays the Cleaning Info menu (see [Figure 2-7 on page 2-10](#)).

4. Press the arrow buttons until the cursor underscores EXPORT CARTRIDGE.
5. Press the SELECT button.

The Export Clean Cartridges screen appears, which lists all reserved cell cleaning cartridges by domain (or drive type), VOLSER, and usage count.

Note: If the usage count for a cleaning cartridge has exceeded its warning count, the export screen will display EXPIRED. You must remove this cartridge from the library.

6. Press the MENU button to exit the Export Clean Cartridges screen.

Cartridges in Reserved Cells and CAP

To check the usage count of all cleaning cartridges (those in the reserved cells and those in the CAP):

1. Press the MENU button to return to the Main Menu.
2. Press the arrow buttons until the cursor underscores CLEANING INFORMATION.

3. Press the SELECT button.

The panel displays the Cleaning Info menu (see [Figure 2-7 on page 2-10](#)).

4. Press the arrow buttons until the cursor underscores CLEAN CARTRIDGE INFO.
5. Press the SELECT button.

The Clean Cartridges screen appears, which lists all installed cleaning cartridges by domain (or drive type), VOLSER, and usage count.

Note: If the usage count for a cleaning cartridge has exceeded its warning count, the export screen will display EXPIRED. You must remove this cartridge from the library.

6. Press the MENU button to exit the Clean Cartridges screen.

Library Personality Information

Viewing library personality information lets you determine the library's vendor and whether the personality module for the Horizon L Series Library Monitor product is present and enabled.

To view the library's personality information:

1. Press the MENU button to return to the Main Menu.
2. Press the arrow buttons until the cursor underscores CONFIGURATION.
3. Press the SELECT button.

The panel displays the Main Configuration Menu.

4. Press the arrow buttons until the cursor underscores PERSONALITY MODULE.
5. Press the SELECT button.

The panel displays the Personality Module Info screen.

6. Press the down arrow to view a second screen of information.
7. To exit the Personality Module Info screen, press the MENU button.

The following status messages might appear on the Personality Module Info screen:

Table 4-6. Personality Module Status/Info Screen

Message	Explanation
Status: PRESENT	A recognizable personality module is attached to the logic card
NOT PRESENT	No personality module is attached to the logic card
UNKNOWN	No valid vendor information has been loaded into this library
Type: NORMAL	No personality upgrade is currently active; the factory-installed personality and vendor information are in effect
UPGRADE	A personality upgrade is available
USED UPGRADE	A personality upgrade is available, but the upgrade has been previously used
WRITE IN PROGRESS	A personality upgrade is in progress
VERSION:	The version number for the personality module. If a personality module is not present, this is the version of the vendor information.
LIBRARY VENDOR ID:	The identity number for the library vendor
LIBRARY VENDOR NAME:	The name of the library vendor
LIBRARY PRODUCT NAME:	If TYPE is NORMAL, this is the product name assigned by the library vendor. If TYPE is UPGRADE, this is the name of the product for which the upgrade is valid.
SCSI VENDOR NAME:	The library vendor name reported on the SCSI or Fibre Channel interface
SCSI PRODUCT NAME:	The library product name reported on the SCSI or Fibre Channel interface
Horizon: ENABLED	The personality upgrade for the Horizon L Series Library Monitor product is available on the installed personality module
DISABLED	The personality upgrade for the Horizon L Series Library Monitor product is not available

Exporting Cleaning Cartridges through the CAP

Note: This procedure assumes that you have:

- Loaded cleaning cartridges into the reserved cells
- Once the cleaning cartridges are loaded, reset the library.

(These two steps enable the Auto Clean function.)

When one or more cleaning cartridges have expired, you can export them from the reserved cells to the CAP. To do export them:

1. Press the MENU button to return to the Main Menu”
2. Press the arrow buttons until the cursor underscores CLEANING INFORMATION.
3. Press the SELECT button.

The panel displays the Cleaning Info menu (see [Figure 2-7 on page 2-10](#)).

4. Press the arrow buttons until the cursor underscores EXPORT CARTRIDGE .
5. Press the SELECT button.

The Export Clean Cartridges screen appears, which lists all reserved cell cleaning cartridges by domain (or drive type), VOLSER, and usage count.

6. Select the cleaning cartridges you want to export by:
 - a. Moving the cursor to the desired cartridge entry on the list
 - b. Pressing the SELECT button.

A selected cleaning cartridge is then highlighted (in reverse video)
 - c. Repeating Steps a and b until you have selected all the cartridges you want to export
7. Press the SELECT button to export the cartridges.

Importing Cleaning Cartridges through the CAP

Note: This procedure assumes that you have:

- Loaded cleaning cartridges into the reserved cells
- Once the cleaning cartridges are loaded, reset the library.

(These two steps enable the Auto Clean function.)

When you want import cleaning cartridges through the CAP into the reserved cells:

1. Enter the console command to unlock the CAP.
2. Press the CAP button on the operator panel to open the CAP.

The *Open* indicator will light.

CAUTION:

Possible halt to operation or damage to components. You must enter the cartridges properly, or else you might damage the robot or the drive or cause the library to stop operating. Use only cartridges designed for your type of drives.

3. Load cartridges into the magazine.

You can do this one of two ways:

- a. Pull out and down on the magazine handle.
- b. Remove the magazine by lifting it out (see [Figure 4-2 on page 4-12](#)).

Note: You can use the snap-on retention cartridge cover to keep cartridges in place when carrying the magazine. Remove the clear cover from the back of the magazine by lifting the side edge. To protect the cartridges, place the slots on one edge of the cover into the grooves on the side of the magazine's top panel and snap the other edge into place.

4. Enter the cartridges into the magazine so that they lie flat, with the VOLSER label facing toward you, the customer label facing down, and the reel facing away from you. (See [Figure 4-3 on page 4-13](#) and [Figure 4-4 on page 4-14](#).)

CAUTION:

Possible damage to the hand assembly. Remove the magazine's retention cover before loading the magazine into the CAP.

5. Return the magazine to its closed position.
6. Press the CAP button on the operator panel to close the CAP.
7. Press the MENU button to return the display to the Main Menu.
8. Press the arrow buttons until the cursor underscores CLEANING INFORMATION.
9. Press the SELECT button.

The panel displays the Cleaning Info menu (see [Figure 2-7 on page 2-10](#)).

10. Press the arrow buttons until the cursor underscores IMPORT CARTRIDGE .
11. Press the SELECT button.

The Import Clean Cartridges screen appears, which lists all reserved cell cleaning cartridges by domain (or drive type), and VOLSER.

12. Select the cleaning cartridges you want to import by:
 - a. Moving the cursor to the desired cartridge entry on the list
 - b. Pressing the SELECT button. A selected cleaning cartridge is then highlighted (in reverse video)
 - c. Repeating Steps a and b until you have selected all the cartridges you want to import

Note: *There is no “undo” available on this menu.* If you select a cartridge by mistake, you must exit the menu by pressing the MENU button. Then you must start again at Step 10.

13. Press the SELECT button to import the cartridges.

Importing Data Cartridges through the CAP

To unlock the CAP, open it, and import data cartridges:

1. Enter the console command to unlock the CAP.
2. Press the CAP A or CAP B button on the operator panel to open the CAP.

The indicator will light.

CAUTION:

Possible halt to operation or damage to components. You must enter the cartridges properly or you might damage the robot or the drive, or cause the library to stop operating. Use only cartridges designed for your type of drives.

Refer to [Figure 4-3 on page 4-13](#) and [Figure 4-4 on page 4-14](#) while performing the following steps.

3. Load cartridges into the magazine.

You can do this one of two ways:

- a. Pull out and down on the magazine handle.
- b. Remove the magazine by lifting it out (see [Figure 4-2 on page 4-12](#)).

Note: You can use the snap-on retention cartridge cover to keep cartridges in place when carrying the magazine. Remove the clear cover from the back of the magazine by lifting the side edge. To protect the cartridges, place the slots on one edge of the cover into the grooves on the side of the magazine's top panel and snap the other edge into place.

4. Enter the cartridges into the magazine so that they lie flat, with the bar code up and the reel facing away from you.

CAUTION:

Remove the retention cover before loading the magazine into the CAP.

5. Return the magazine to its closed position.
6. Press the CAP A or CAP B button on the operator panel to close the CAP.

Note: StorageTek strongly advises that you do *not* enter unlabeled cartridges. Your client software determines what happens when you enter a cartridge with an unreadable label. Under ordinary conditions, the camera on the hand audits the CAP and recognizes that a cartridge is present, but the hand does not move it. You must remove the cartridge from the CAP.

In this situation, your software might direct the library to stop operating. Some software might prompt you to type in a label number when no VOLSER is read. Typing in a label number might cause a problem later during an audit because the camera still will not be able to read the unreadable VOLSER on the cartridge.

Figure 4-2. Removing the CAP Magazine (C65027)

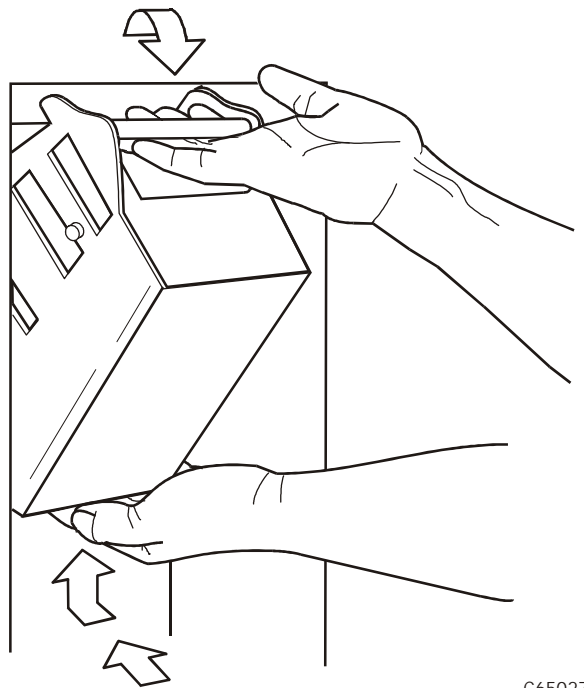

C65027

Figure 4-3. Entering DLT/SDLT Cartridges into the CAP Magazine (C65052)

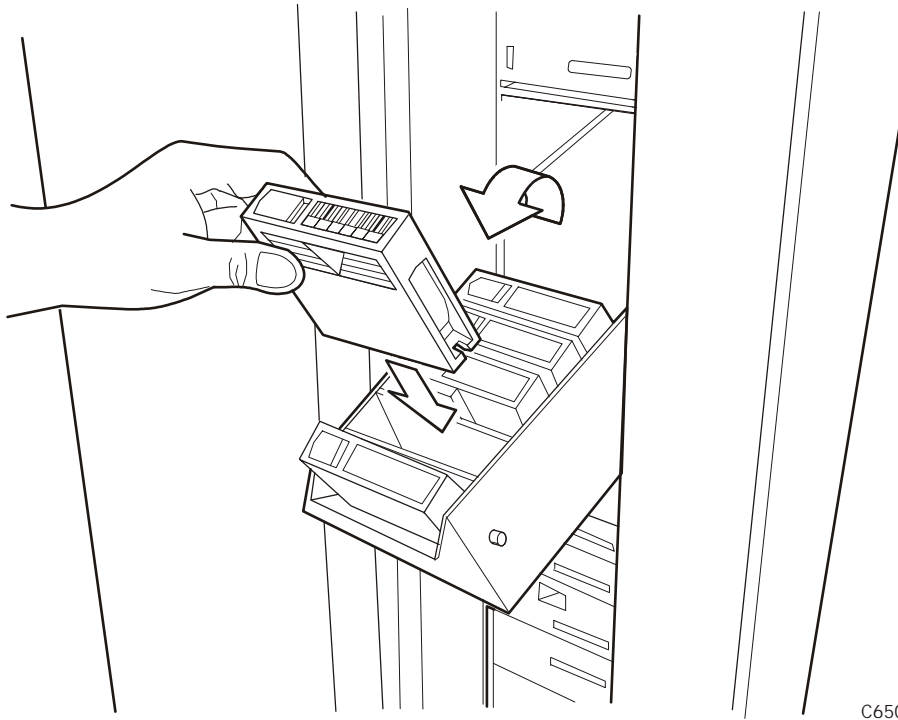

C65052

Figure 4-4. Entering 9840/T9840B/T9940 Cartridges into the CAP Magazine (C65135)

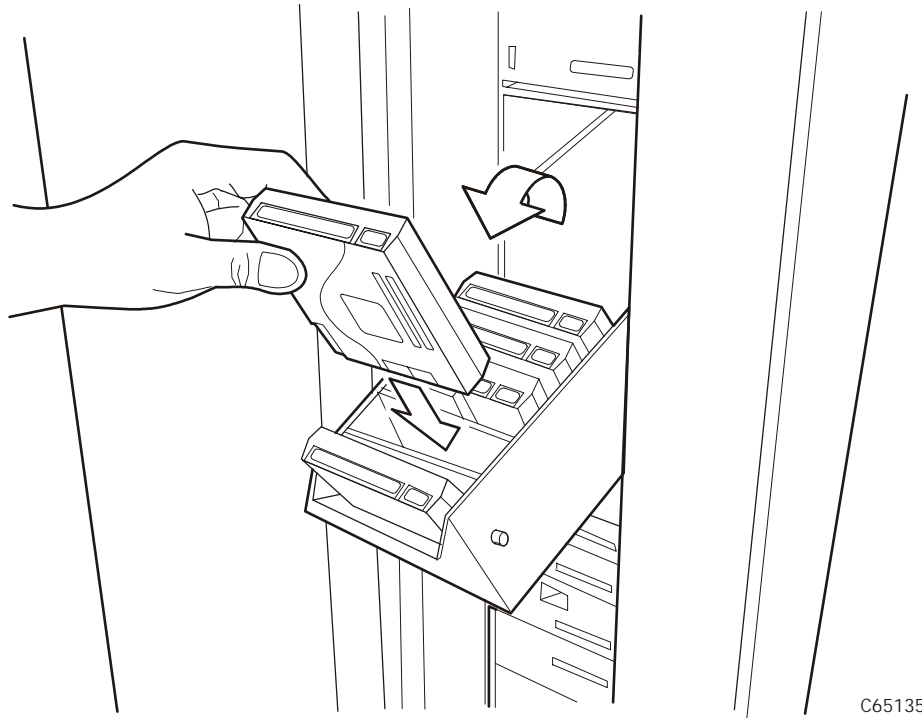

C65135

Figure 4-5. Entering Ultrium Cartridges into the CAP Magazine (C65302)

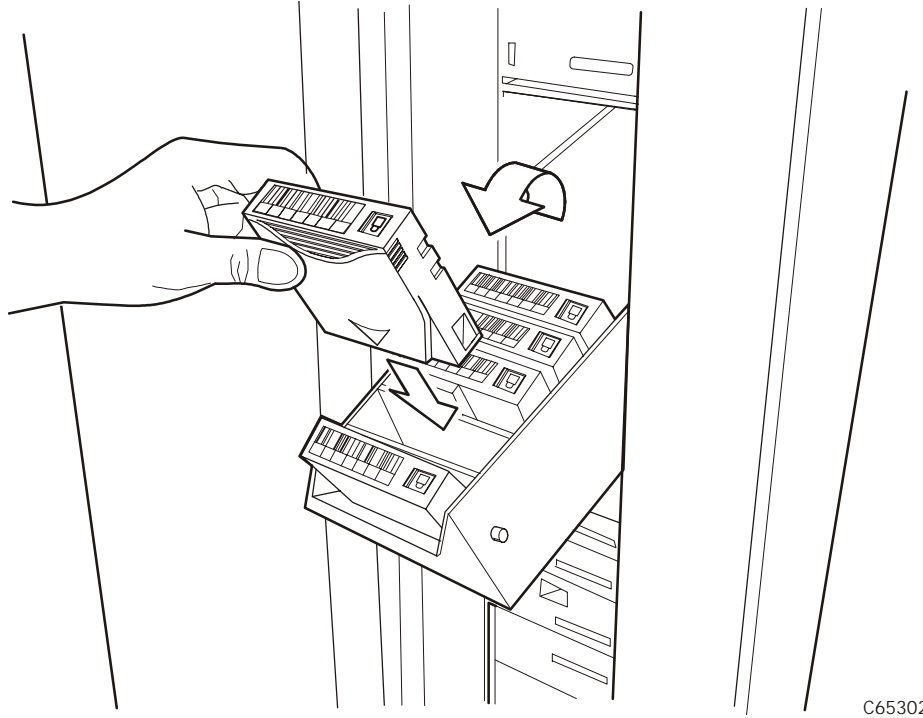

C65302

Exporting Data Cartridges through the CAP

To export data cartridges through the CAPt:

1. At the console, enter the VOLSERS of the cartridges you require.
The robot will retrieve the cartridges and insert them into the CAP.
2. Enter the console command to open the CAP.
This will unlock the CAP.
3. Press the CAP A or CAP B button on the operator panel to open the CAP.
4. Remove or pull down the magazine and remove the cartridges and store them *outside* the tape library (refer to [“Storage of Cartridges” on page A-22](#)).
5. Repeat these steps until you have removed all the required cartridges.
6. Press the CAP button to close the CAP
7. Refer to your console and your software documentation for further instructions.

Manually Cleaning a Drive

If you have not enabled the Auto Clean function on the library, then the library status screen will display CLEAN NEEDED whenever a drive requires cleaning.

To manually clean this drive:

1. Enter the console command to open the CAP.
This will unlock the CAP.
2. Press the CAP button on the operator panel to open the CAP.
3. Insert the required cleaning cartridge into the CAP.
4. Press the CAP button to close the CAP.
5. Press the MENU button until the Main Menu displays.
6. Press the arrow buttons until the cursor underscores DIAGNOSTICS.
7. Press the SELECT button.

The panel displays the Main Diagnostics Menu (see [Figure 2-8 on page 2-11](#)).

8. Press the arrow buttons until the cursor underscores DRIVE DIAGNOSTICS.
9. Press the SELECT button.

The screen will display a list of all installed drives.

10. Use the arrow buttons to highlight the desired drive.
11. Press the SELECT button.

The Diagnostics for Drive menu appears.
12. Press the arrow buttons until the cursor underscores CLEAN DRIVE.
13. Press the SELECT button.

A message screen will appear to inform you that the drive will be cleaned at the next opportunity.

When cleaning is completed, the robot will return the cleaning cartridge to the CAP.

If you want to clean another drive (of the same type), press the MENU button to return to the list of drives, and repeat Steps 10 through 13.
14. When drive cleaning is completed, press the CAP button to open the CAP.
15. Remove the cleaning cartridge and make a record of how many times it has been used.
16. Press the CAP button to close the CAP.

Reviewing FSC Logs

A StorageTek service representative might ask you to review the library's fault symptom code (FSC) log so that you can better analyze library-related problems. The FSC log records significant events and errors that the library has experienced during operation.

To review the FSC log:

1. Press the MENU button until the Main Menu displays.
2. If necessary, press the arrow buttons until the cursor underscores FSC LOG.
3. Press the SELECT button.

The panel displays the FSC logs screen (see [Figure 2-4 on page 2-6](#)).
4. Use the arrow buttons to scroll through the log.

Here is a sample entry on the FSC logs screen, followed by an explanation of the entries:

```
3329 03 NONE
03/01/2004 14:46:14
```

- 3329** This four-character code is the FSC.
- 03** This value indicates the number of times this FSC has occurred.
- NONE** This message indicates which, if any, mechanical device was involved.
- 03/01/2004** These digits indicate the date the FSC occurred. The fields from left to right are month, day, and year.
- 14:46:14** These digits indicate the time the FSC occurred. The fields from left to right are hour, minutes, and seconds.

Running Diagnostic Tests

Diagnostic tests let you exercise certain aspects of the library's operation. Tests are listed in [Table 4-7](#).

Table 4-7. L700e Library Drive Diagnostic Tests

Test	Description
Clean Drive	This function is not a test. It moves a specified cleaning cartridge from the CAP to a drive and initiates drive cleaning. When cleaning is completed, it will return the cleaning cartridge to the CAP. This routine does <i>not</i> require the library to be offline.
Mount	Mounts a diagnostic tape to the selected drive.
Dismount	Dismounts a diagnostic tape from the selected drive.
Run Drive Check	Determines whether the specific drive is functioning. This test applies to DLT 8000 and 9840/T9840B/T9940* drives only.
Mount-Dismount	Mounts and dismounts a diagnostic tape on the selected drive.
Note: 9840/T9840B and T9940 drives must have firmware version 1.28 or higher.	

CAUTION:

Potential system problem: Diagnostic tests should be performed only by trained personnel.

Before performing the diagnostic tests, be sure that the library and drives are offline.

Running Drive Diagnostic Tests

To run a diagnostic test on a drive:

1. Place the library and drives offline.
2. Press the MENU button until the Main Menu displays.
3. Press the arrow buttons until the cursor underscores DIAGNOSTICS.
4. Press the SELECT button.

The panel displays the Main Diagnostics Menu.

5. Press the arrow buttons until the cursor underscores DRIVE DIAGNOSTICS.
6. Press the SELECT button.

The screen will display a list of installed drives.

7. Use the arrow buttons to highlight the desired drive.
8. Press the SELECT button.

The Diags for Drive menu appears.

9. Press the arrow buttons until the cursor underscores the desired test. For a description of the available tests, see [Table 4-7 on page 4-18](#).
10. Press the SELECT button.

If you selected MOUNT/DISMOUNT LOOP, an editing screen will appear:

- a. Use the arrow buttons to enter the desired value. (The up arrow button increases the value; the down arrow button decreases the value.)
 - b. Press the SELECT button.
11. You will be prompted to confirm that you want the library in Maintenance Mode (offline) before beginning the test (ARE YOU SURE?). Confirm this by pressing the SELECT button. (You may press the MENU button to abort.)
 12. Wait until the test is completed; the screen will display a message that either the test completed successfully or, if a problem occurred, the screen will display an error message and, in some cases, an FSC code.

Running a Get-Put Loop

During a Get-Put loop, the hand loads and unloads a cartridge from a storage cell. This tests the functionality of the hand assembly.

To run a Get-Put loop:

1. Place the library and drives offline.
2. Press the MENU button until the Main Menu displays.
3. Press the arrow buttons until the cursor underscores `DIAGNOSTICS`.
4. Press the SELECT button.
The panel displays the Main Diagnostics Menu.
5. Press the arrow buttons until the cursor underscores `GET PUT LOOP`.
6. Press the SELECT button.
The Get-Put Mode screen will appear.
7. You will be prompted to confirm that you want the library in Maintenance Mode (offline) before beginning the test (`ARE YOU SURE?`). Confirm this by pressing the SELECT button. You may press the MENU button to abort.
8. Wait until the test is completed; the screen will display `TEST COMPLETE` or, if a problem occurred, an FSC code.

Operating in Demo Mode

CAUTION:

***Potential for error.* Running the library in Demo Mode causes the data cartridges to be rearranged. After Demo Mode is completed, you must reset the library and enter the client command to upload library audit data to the client.**

With the library in Demo Mode (demonstration mode), the hand takes a data cartridge from a storage cell, moves the cartridge, and places the cartridge back into a different storage cell.

To operate in Demo Mode:

1. Place the library and drives offline.
2. Press the MENU button until the Main Menu displays.
3. Press the arrow buttons until the cursor underscores `DIAGNOSTICS`.
4. Press the SELECT button.
The panel displays the Main Diagnostics Menu.
5. Press the arrow buttons until the cursor underscores `DEMO MODE`.
6. Press the SELECT button.
The Demo Mode menu appears.
7. Use the arrow buttons to enter the desired number of loops. The up arrow button increases the value by 100; the down arrow button decreases the value by 100.

Note: StorageTek does not recommend looping tests excessively.

8. Press the SELECT button.
9. You will be prompted to confirm that you want the library in Maintenance Mode (offline) before beginning the test (ARE YOU SURE?). Confirm this by pressing the SELECT button. (You may press the MENU button to abort.)
10. Wait until the test is completes. The screen will display TEST COMPLETE. or, if a problem occurred, an FSC code
11. Press the RESET button to reset the library.

■ Powering off the Library

To power off the library:

1. Enter the command at the system console to remove the tape library and drives from online status.
2. Press down on the switch or switches (circuit breakers) behind the right front door of the tape library.

■ Operating in Manual Mode

The following section describes operations you can perform when the tape library is in manual mode. Manual mode occurs when the tape library is not online.

When the library is offline, you might have to:

- Open the front door
- Move the robot
- Locate a cartridge in the storage cells
- Remove a cartridge from the hand
- Mount a cartridge in a drive
- Dismount a cartridge from a drive

Before starting any of these tasks, you must take precautions against electrostatic discharge (ESD).

CAUTION:

Potential static electricity damage to electrical components: Take precaution against potential ESD damage by touching unpainted metal on the library frame *before* reaching into the library or touching any drives. Avoid touching any electrical components.

After you have opened a library door:

1. With your finger, touch a gray, unpainted metal surface, such as the library frame just inside the front door.
2. Keep your body movement to a minimum as you touch the drives or library components.

Antistatic wrist straps with clip-on ends are commercially available.

Opening the Library Front Doors

You must open the front doors to perform manual operations. Refer to [Figure 4-6 on page 4-23](#) as you perform this procedure.

1. Make sure all jobs have ended and that the tape library is offline.
2. Open the tape library right front door by pulling on the left side of the door.
3. Open the tape library left front door by using a latch key to unlock both locks. Turn the key counterclockwise to unlock them, then pull open the door.

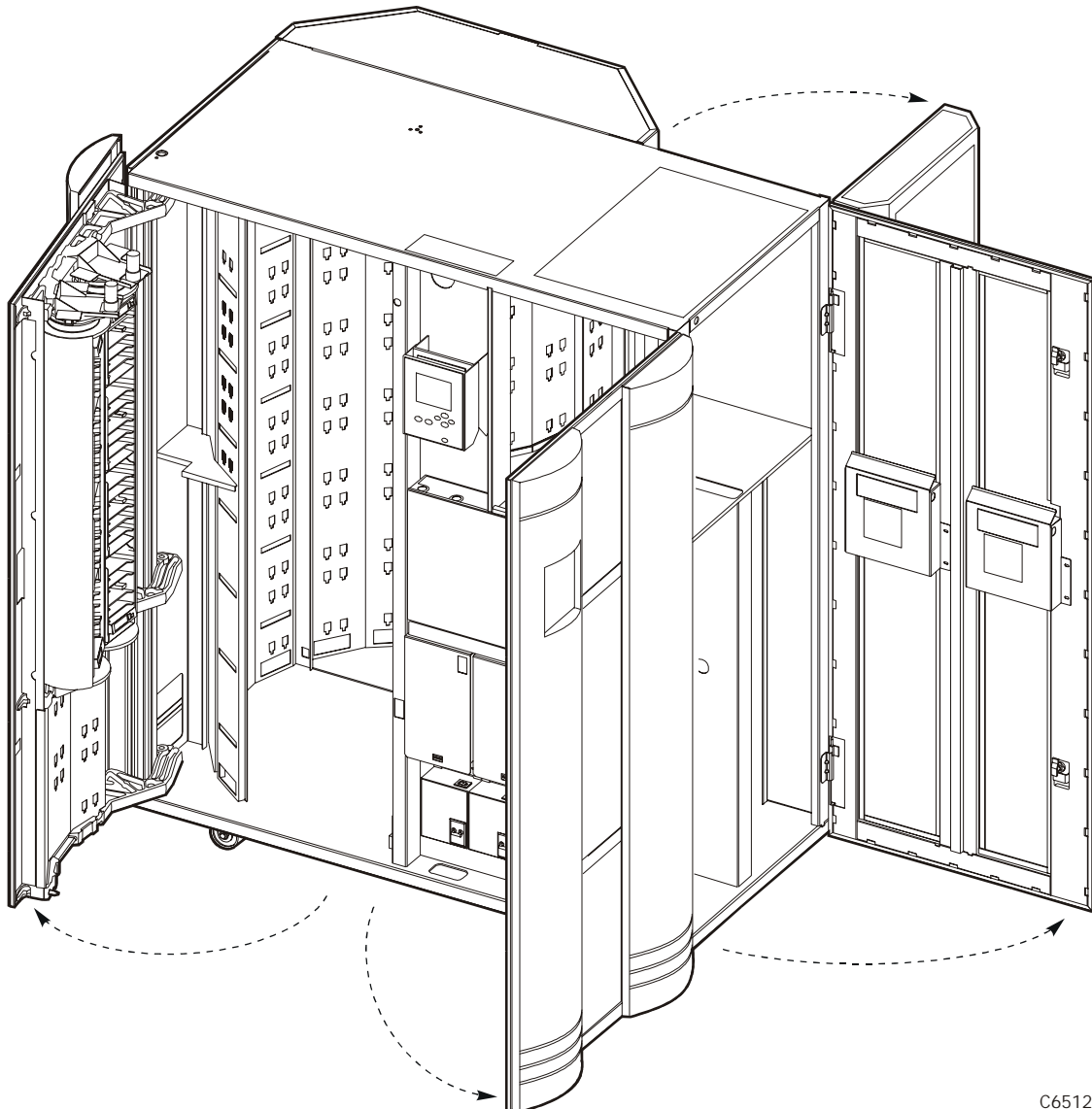
Figure 4-6. Opening the Access Doors (C65125)

C65125

Moving the Robot

After you open the tape library doors, you might need to move the robot to make it easier to access the cartridges or the drives.

Read and observe the following caution before you attempt to move any portion of the robot.

CAUTION:

Potential equipment damage: To prevent damaging the hand or Z carriage, make sure the reach mechanism on the hand is fully retracted

before moving any part of the robot. Push the gripper mechanism into the retracted position. If the tape library goes offline due to a power failure, the reach mechanism might be extended into a storage cell or drive. If the robot is rotated when this condition exists, the hand could be damaged.

Move the Z column and Z carriage only as shown in [Figure 4-7](#) and [Figure 4-8](#) on page 4-25.

Take precaution against potential ESD damage by touching gray, unpainted metal on the library frame before reaching into the library. Avoid touching any electrical components.

Raising and Lowering the Hand-camera Assembly

If you need to raise or lower the hand, *slowly and carefully* move it by placing your fingers on the hand-camera assembly as shown in [Figure 4-7](#).

Figure 4-7. Raising and Lowering the Hand-camera Assembly (C65019)

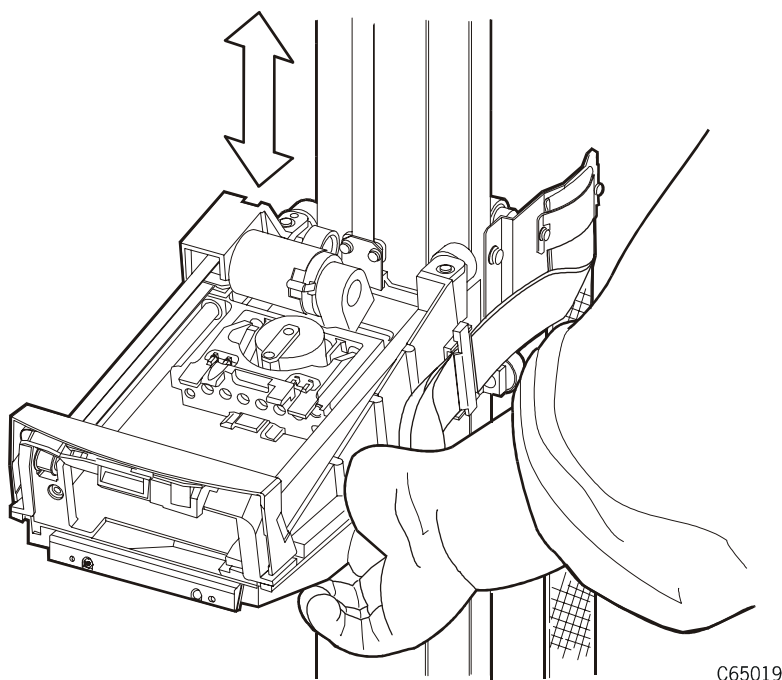

Rotating the Z Column

If you need to rotate the Z column, grasp it and *carefully* rotate it, as shown in [Figure 4-8](#).

The Z column does not rotate a full 360 degrees. If the column meets resistance and stops before reaching the desired position, it has contacted a stopping mechanism. Do *not* force it. Rather, rotate the column in the opposite direction.

Figure 4-8. Rotating the Z Column (C65084)

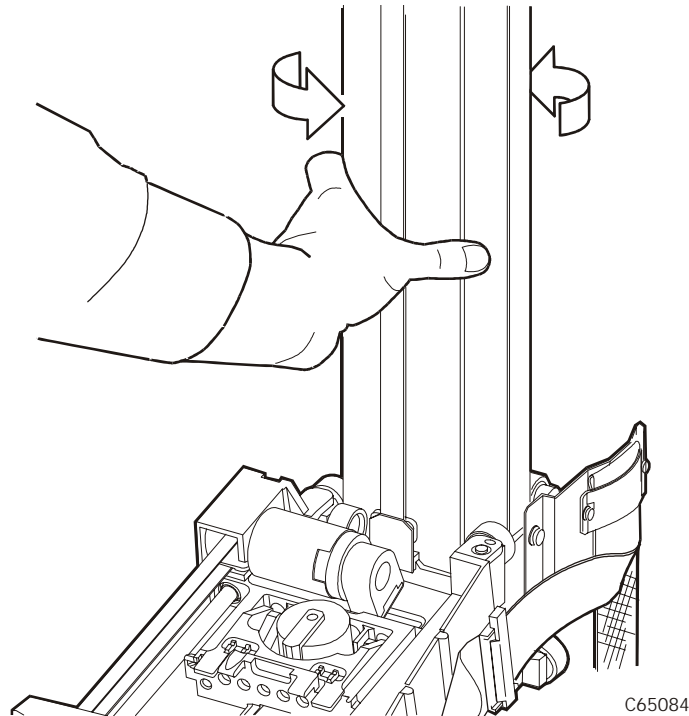

Locating a Cartridge in the Storage Cells

[Figure 1-3 on page 1-7](#) and [Figure 1-4 on page 1-8](#) show the locations of the panels, rows, and columns of the cartridge storage cells in the library. The decal at the top of each column also provides location information. To remove a cartridge from a storage cell, slide out the cartridge.

Removing a Cartridge from the Hand

If the library loses power or goes offline, a cartridge might be left in the hand. You can remove it from the hand and manually mount it into a drive for a read/write operation.

CAUTION:

Possible equipment damage: Follow the procedures described in [“Moving the Robot” on page 4-23](#). Failing to do so could damage the hand.

Make sure you do not touch any electronic components on the hand assembly. The components could easily be damaged.

To remove a cartridge from the hand:

1. Rotate the Z column; move the hand until it is facing the front door.
2. Push on the back of the reach mechanism (as shown in [Figure 4-9](#)) until the gripper is extended to its full position, as shown in [Figure 4-10 on page 4-27](#).

Figure 4-9. Extending the Gripper (C65054)

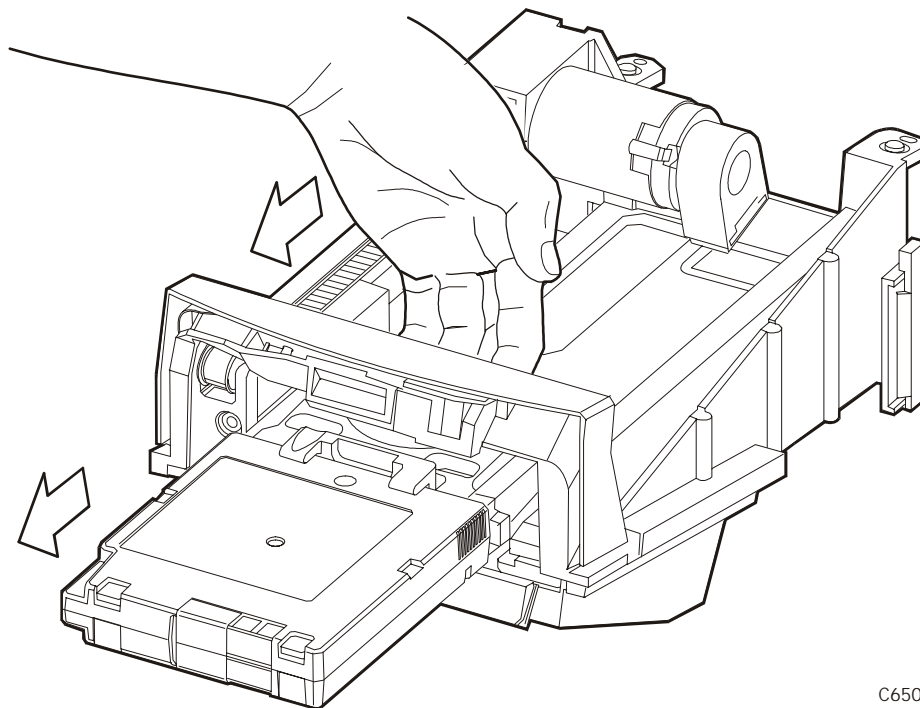

C65054

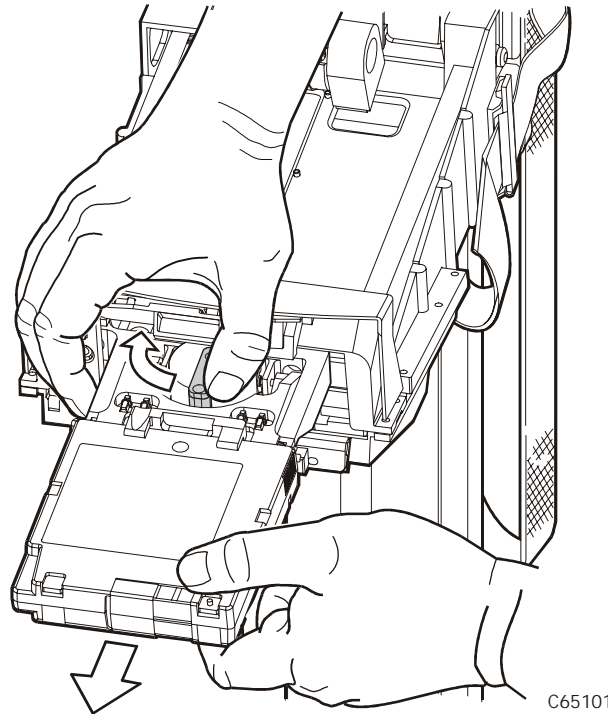
Figure 4-10. Removing a Cartridge from the Hand (C65101)**CAUTION:**

Heated components: If the robot has been active, the solenoid switch might be hot to the touch. Wait for the solenoid to cool before touching it.

3. Hold the solenoid on top of the reach mechanism with one hand and grasp the cartridge with the other. Rotate the solenoid switch clockwise until the cartridge is released from the gripper, as shown in [Figure 4-10](#).

CAUTION:

Potential equipment damage: Make sure the gripper mechanism is fully retracted. If it is left extended and you turn the robot, the gripper mechanism will strike a storage cell. If it is left extended and the hand is facing the tape library door when it is closed, the door will strike the gripper mechanism.

4. Push the gripper mechanism back into the hand until the mechanism is fully retracted.

Loading/Unloading Cartridges Manually

When the library is offline, you can—after taking adequate precautions—load a cartridge into a drive or unload a cartridge from a drive. The following pages provide manual load and unload procedures for DLT, Ultrium, and 9840/T9840B/T9940 drives.

Note: If you manually load any cartridges into a drive, you should manually unload them from the drive when the drive's operation is finished. Place them into a cell or remove them from the library.

Loading a Cartridge into a Load Handle Drive

Some drives in the library contain load handle mechanisms to assist the drive in loading cartridges. The load lever can be seen on the front of these drives. Follow the directions below to manually load a drive that contains a load handle.

CAUTION:

Potential equipment damage: Before you load a cartridge into the drive, you must make sure power is on and the *Operate Handle* indicator is steadily on (not flashing).

To load a cartridge into a load handle drive:

1. Obtain the cartridge VOLSER, location, and drive number from the console.
2. Open the tape library right front door by pulling on the left side of the door.
3. Open the library left front door by using a latch key to unlock both locks. See [Figure 4-6 on page 4-23](#). Turn the key counterclockwise to unlock them, then pull open the door.
4. Locate the cartridge (see [“Locating a Cartridge in the Storage Cells” on page 4-25](#)).
5. Make sure the DLT handle is up (see [Figure 4-11 on page 4-29](#)) and the *Operate Handle* indicator is steadily on.

Note: If the handle is in the down position, wait for the *Operate Handle* indicator to remain on steadily before moving it to the up position (see [Figure 4-11 on page 4-29](#)). If the *Operate Handle* indicator is flashing while the handle is up, move the handle to the down position and wait for the *Operate Handle* indicator to remain on steadily. Then move the handle to the up position.

Figure 4-11. Drive with Load Handle (C65232)

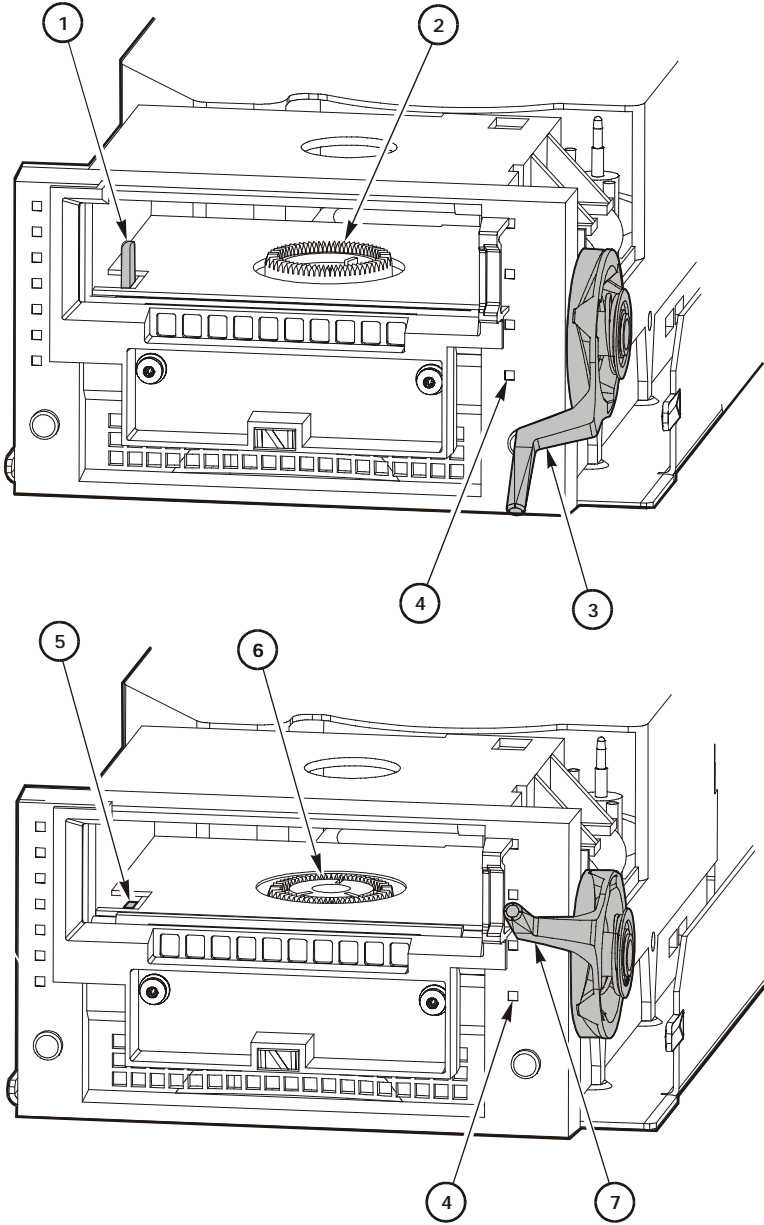

C65232

- 1. Cartridge hook (up)
- 2. Hub (up)
- 3. Handle (down)
- 4. Operate handle indicator
- 5. Cartridge hook (down)
- 6. Hub (down)
- 7. Handle (up)

CAUTION:

Potential equipment damage: You must insert the cartridge properly or you will damage the drive. Use only DLT cartridges for DLT drives. Make sure the cartridge has a readable VOLSER label.

6. Hold the cartridge so that the VOLSER label is facing you and the write protect switch is on the right side of the cartridge, as shown in [Figure 4-12 on page 4-30](#).
7. Insert the cartridge into the drive and push the cartridge into the back of the drive until it is firmly seated.
8. Lower the drive handle.

Figure 4-12. Loading a Cartridge into a Load Handle Drive (C65137)

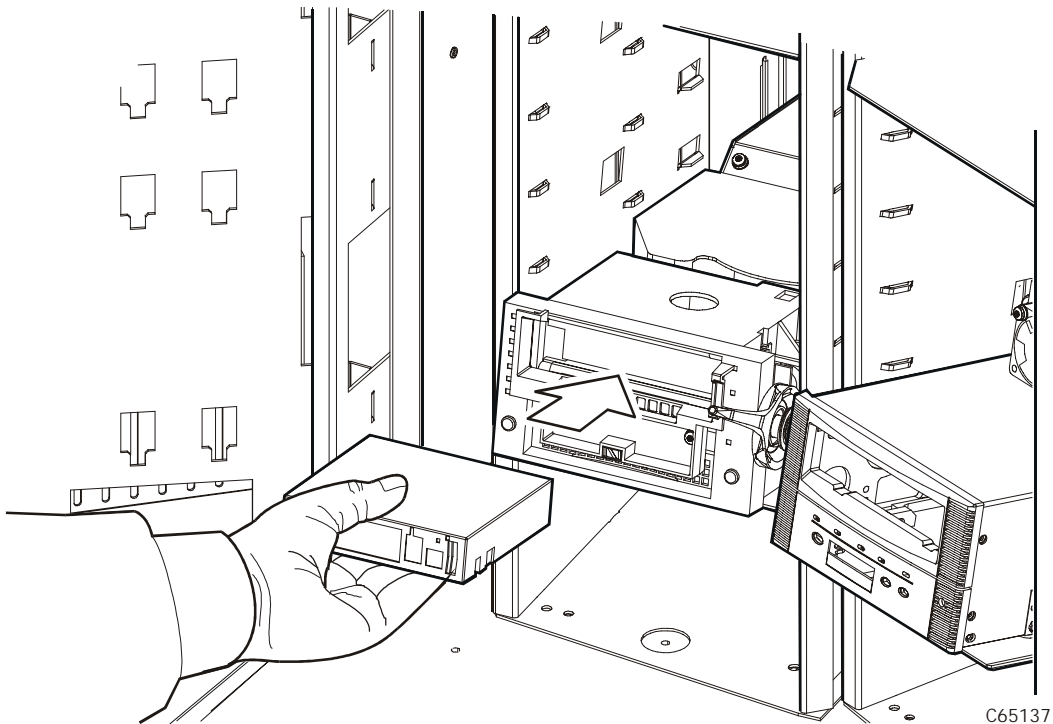

Unloading a Cartridge from a Load Handle Drive

To unload a cartridge from a load handle drive:

1. Obtain the drive number from the console and place the drive offline.
2. Open the tape library right front door by pulling on the left side of the door.
3. Open the library left front door by using a latch key to unlock both locks. See [Figure 4-6 on page 4-23](#). Turn the key counterclockwise to unlock them, then pull open the door.

4. Locate the desired drive.
5. Press the Unload button on the drive.
6. Wait (about 12 seconds) for the *Operate Handle* indicator to remain steadily on.

CAUTION:

Potential tape or equipment damage: Wait five seconds before pulling the cartridge out of the drive. Immediately removing the cartridge may damage the cartridge or drive leaders.

7. Raise the handle. The cartridge will eject about 4 cm (0.5 in.).
8. Gently pull the cartridge from the drive.

Note: If the cartridge does not come out of the drive, remount the cartridge and return to Step 5.
9. Store the cartridge *outside* the tape library (refer to [“Storage of Cartridges” on page A-22](#)).

Loading a Cartridge into a 9840/T9840B/T9940 Drive

To load a cartridge in a 9840/T9840B/T9940 drive:

1. Obtain the cartridge VOLSER, location, and drive number from the server console.
2. Open the tape library right front door by pulling on the left side of the door.
3. Open the library left front door by using a latch key to unlock both locks. See [Figure 4-6 on page 4-23](#). Turn the key counterclockwise to unlock them, then pull open the door.
4. Locate the cartridge (see [“Locating a Cartridge in the Storage Cells” on page 4-25](#)).
5. Insert the cartridge into the 9840/T9840B/T9940 drive using the direction shown in [Figure 4-13 on page 4-32](#).
6. Wait for one of the following messages to display on the drive’s front panel and take the appropriate action, if necessary:
 - The Ready F (File Protected) message displays when a write-protected cartridge loads successfully.
 - The Ready U (File Unprotected) message displays when a cartridge that is not write-protected loads successfully.
 - The Ready A (VolSafe-enabled) message displays when a write-enabled VolSafe cartridge loads successfully.

- The NTRReady message displays when the tape in the cartridge has lost tension. Follow the instructions outlined in the *9840/T9840B Tape Drive User's Reference Manual*, PN 95739, or the *T9940 Tape Drive Operator's Guide*, PN 95989, to correct this condition.
- The LOADxxxx message displays when the cartridge unsuccessfully loads, where the xxxx is a fault symptom code. Follow the instructions outlined in the *9840/T9840B Tape Drive User's Reference Manual*, PN 95739, or the *T9940 Tape Drive Operator's Guide*, PN 95989 to correct this condition.

Figure 4-13. Loading a Cartridge into the 9840/T9840B/T9940 Drive (C65138)

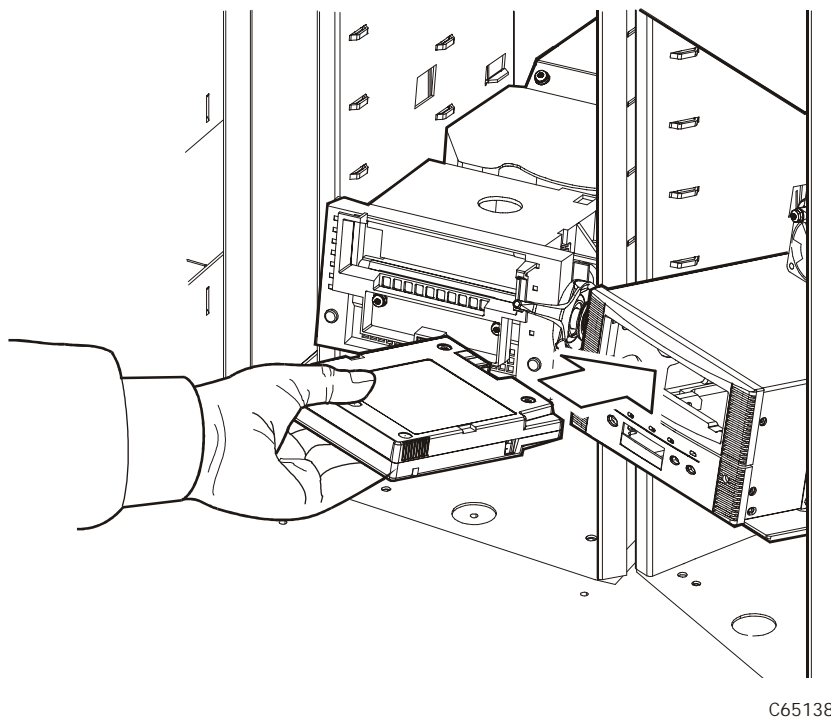

Note: T9840B drives have purple switches; 9840 drives contain yellow switches.

Unloading a Cartridge from a 9840/T9840B/T9940 Drive

To unload a cartridge from a 9840/T9840B/T9940 drive:

1. Make sure that the 9840/T9840B/T9940 drive is not selected by the client.
2. Obtain the drive number from the server console and place the drive offline.
3. Open the tape library right front door by pulling on the left side of the door.
4. Open the tape library left front door by using a latch key to unlock both locks. See [Figure 4-6 on page 4-23](#). (Turn the key counterclockwise to unlock them, then pull open the door.)

5. Press the Unload switch on the front panel of the drive.

One of the following conditions can occur:

- After the tape rewinds, the cartridge ejects from the 9840/T9840B/T9940 drive. Remove the cartridge from the 9840/T9840B/T9940 drive.
- The cartridge fails to eject after the tape rewinds. Refer to the *9840/T9840B Tape Drive User's Reference Manual*, PN 95739, or the *T9940 Tape Drive Operator's Guide*, PN 95989 to correct this condition.
- If the Unload switch is pressed during a write operation, the 9840/T9840B/T9940 drive tries to write the remaining data before the cartridge unloads. If the `UnWrxxxx` (Unwritten Data) message displays, where `xxxx` is the fault symptom code, the attempt failed and some data remains unwritten to the tape.

For more information about recovering from an Unwritten Data condition, refer to the *9840/T9840B Tape Drive User's Reference Manual*, PN 95739 or the *T9940 Tape Drive Operator's Guide*, PN 95989.

Loading a Cartridge into an Ultrium Drive

To load a cartridge into a Ultrium drive:

1. Obtain the cartridge VOLSER, location, and drive number from the server console.

CAUTION:

***Possible equipment problem:* You must open the library's front door before attempting to manually mount a cartridge to an Ultrium drive. A unique communication between the library and drive prepares the drive for manual operation.**

2. Open the tape library right front door by pulling on the left side of the door.
3. Open the library left front door by using a latch key to unlock both locks. See [Figure 4-6 on page 4-23](#). Turn the key counterclockwise to unlock them, then pull open the door.
4. Locate the cartridge (see ["Locating a Cartridge in the Storage Cells" on page 4-25](#)).
5. Insert the cartridge into the Ultrium drive using the direction shown in [Figure 4-14 on page 4-34](#).

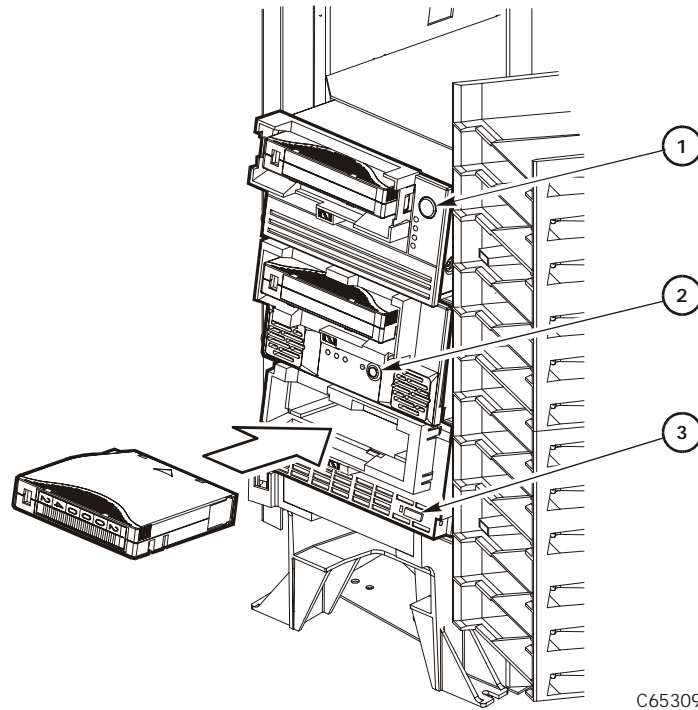
Figure 4-14. Loading a Cartridge into an Ultrium Drive (C65309)

1. Cartridge dismount button on HP Ultrium drive
2. Cartridge dismount button on Seagate Ultrium drive
3. Cartridge dismount button on IBM Ultrium drive

Unloading a Cartridge from an Ultrium Drive

To unload a cartridge from an Ultrium drive:

1. Make sure that the drive is not selected by the client.
2. Obtain the drive number from the server console and place the drive offline.
3. Open the tape library right front door by pulling on the left side of the door.
4. Open the tape library left front door by using a latch key to unlock both locks. See [Figure 4-6 on page 4-23](#). (Turn the key counterclockwise to unlock them, then pull open the door.)
5. Press the Unload button on the front panel of the drive.

One of the following conditions can occur:

- After the tape rewinds, the cartridge ejects from the drive. Remove the cartridge from the drive.
- The cartridge fails to eject after the tape rewinds. Refer to the appropriate manufacturer's manual to correct this condition.

Returning the Library to Online Status

To return the tape library online for automated operations:

1. Refer to your specific drive publications for instructions on making the drives ready. For a DLT drive, make sure the *Operate Handle* light is on and the handle is up.

Note: If you manually load any cartridges, you must manually unload them and store them in a storage cell or remove them from the library.

2. Close and lock the tape library doors. The robot will perform an audit of the cells.
3. Place the tape library online by entering the command at the server operator console.
4. Give the client command to upload the audit data to the client.
5. Refer to your specific software publications for instructions on replacing the cartridges you removed and on inserting the cartridges into the storage cells.

This page intentionally left blank.

This chapter describes what to do if problems occur with the tape library. In some cases, you might be able to correct the problem. In other cases, you must contact your service representative, as described in this chapter.

When the problem is caused by cartridge tapes, refer to [Appendix A, “Cartridge Tape Information.”](#) When the problem is caused by cartridge tape drives, refer to your tape drive operator’s guide.

Most of the time, a fault symptom code (FSC) will appear on the tape library operator panel display. Write down the display information, and give the information to your customer representative or to the staff at the StorageTek Remote Center. Write down the FSC as soon as it appears.

■ Customer Support Services

The Call Center for Customer Support Services (CSS) is available 24 hours a day, seven days a week, to customers with StorageTek maintenance contracts and to StorageTek employees. You can find additional information about the CSS on StorageTek’s external Web site at:

<http://www.support.storagetek.com>

■ Customer Initiated Maintenance

Customer Initiated Maintenance begins with a telephone call from you to the StorageTek CSS. You receive immediate attention from qualified StorageTek personnel, who record problem information and respond with the appropriate level of support.

To contact the CSS about a problem:

1. Use the telephone to call the StorageTek Customer Support Services at:

 **800.525.0369** (from within the United States)

 **303.673.4056** (from outside the United States)

2. Describe the problem to the call taker. The call taker will ask several questions and will either route your call to or dispatch a support representative.

If you have the following information when placing a service call, the process will be much easier:

Account name	_____
Site location number	_____
Contact name	_____
Telephone number	_____
Equipment model number	_____
Device address	_____
Device serial number (if known)	_____
Urgency of problem	_____
Fault Symptom Code (FSC)	_____
Problem description	_____

■ StorageTek's Worldwide Offices

You may contact any of StorageTek's worldwide offices to discuss complete storage, service, and support solutions for your organization. You can find address and telephone number information on StorageTek's external Web site at:

<http://www.storagetek.com/global/>

Cartridge Tape Information

A

This appendix describes how to prepare, inspect, store, clean, and repair cartridges. It also lists cartridge specifications.

Note: Do *not* use DATA D3 (helical recording) cartridges or 3480 cartridges in the L700 library.

■ Cartridge Tapes and Labels

StorageTek created starter kits to help the customer start using their library. Starter kits have pre-labeled cartridges with number ranges that are unique for each kit (so multi-media applications will not experience duplicate numbers).

Note: The following notes apply to the starter kits and tables on the following pages.

- LTO cartridges are available only in the 100 GB capacity.
- Cleaning and diagnostic kits have one labeled cleaning cartridge and one labeled diagnostic cartridge with a volume serial number of 0 (zero) for each. Extra cleaning and diagnostic labels are sent with each library.
- Labeled LTO cartridges are available with either vertical or horizontal label formats; the label orientation is a function of how the cartridges are stored outside the library, not inside the library.

Cleaning and Diagnostic Cartridge Starter Kits

StorageTek offers cleaning and diagnostic cartridge kits that supply cartridges and labels for each drive type; these are listed in [Table A-1](#).

Table A-1. Cleaning and Diagnostic Cartridge Starter Kits

Tape Drive	Kit
DLT	313688001
SDLT 220	313688101
HP Ultrium - OEM	313688201
HP LTO Ultrium (Vertical labels)	313688301
Seagate LTO Ultrium (Vertical labels)	313688401
IBM LTO Ultrium (Vertical labels)	313688501

Cartridge and Label Part Numbers

StorageTek also offers individual cartridges and labels, along with data cartridge kits for each drive type; these are listed in [Table A-2](#).

Table A-2. Cartridge and Label Part Numbers

Description	Cartridges	Labels		20 Tape Starter Kit
		Vertical	Horizontal	
Data Cartridges:				
DLT1 (Benchmark)	313126301	313126702		313688801
DLTtape III	313126102	313126502		
DLTtape IV	313126301	313126702		313711501
Super DLT	100099701	309898101		313689001
LTO Ultrium HP Branded	100098701	313672202		313689101
LTO Ultrium Fuji	100098901	313672101	313700501	313689201 (vertical)
LTO Ultrium Maxell	100099101			313684001 (horizontal)
Cleaning Cartridges:				
DLT	313126401	313126902		
DLT1 (Benchmark)	100099401	309898001		
Super DLT				
HP LTO Ultrium (OEM)	100098801	313671802		313689101
HP LTO Ultrium	100098801	313671701	313699901	
IBM LTO Ultrium	100099801	313671901	313700001	
Seagate LTO Ultrium	100099201	313672001	313700101	
Diagnostic Cartridges:				
DLT	313126301	313126802		
DLT1 (Benchmark)	313126301	313730401		
Super DLT	100099701	313712501		
HP LTO Ultrium (OEM)	100098701	313673102		
HP LTO Ultrium	100098901	313672901	313700601	
IBM LTO Ultrium	100098901	313672901	313700601	
Seagate LTO Ultrium	100098901	313672901	313700601	
Note: For 9840/T9840B/T9940 cartridges, check drive documentation				

■ Colored Cartridge Specifications

Colored cartridges are approved only if the measured reflection density is greater than 0.10 for DLT cartridges and 1.50 for 9840/T9840B cartridges, as measured by an X-Rite 404G color reflection densitometer. Measurements are:

Band width	ANSI Status T Wideband (380 to 780 nanometers)
Measuring range	Density (0.00 to 2.50) D
Accuracy	± 0.02 D
Repeatability	± 0.01 D
Aperture diameter	3.4 mm

For more information about colored cartridges, contact your StorageTek marketing representative.

■ Preparing Cartridges

The following pages describe how to prepare a cartridge for use in the tape library.

Handling a Cartridge

Improper handling of cartridges can result in a loss of data or damage to a library component.

To handle a cartridge correctly:

- Make sure the leader block is latched every time you pick up a cartridge.
- Keep cartridges *clean*.
- Inspect a cartridge before each use and *never* put a damaged cartridge into a drive or tape library. Never release a tape leader and pull tape from a cartridge.
- Never open a cartridge.
- Do not handle tape that is outside the cartridge; the tape edge might be damaged.
- Do not expose the tape or cartridge to direct sunlight or moisture.
- Do not expose a recorded cartridge to magnetic fields; this might destroy data on the tape.

Inspecting a Cartridge

A defective or dirty cartridge can damage a drive. Always inspect a cartridge before inserting it into a drive or inserting it into a tape library. Refer to [Figure A-1 on page A-5](#) through [Figure A-4 on page A-8](#). Look for:

- Cracked or broken cartridge
- Broken leader
- Broken tape access door
- Damaged file-protect selector or write-protect switch
- Liquid in the cartridge
- Labels not firmly attached or extending over the cartridge edge
- Any other obvious damage

Figure A-1. DLT and SDLT Cartridge Components (C65004)

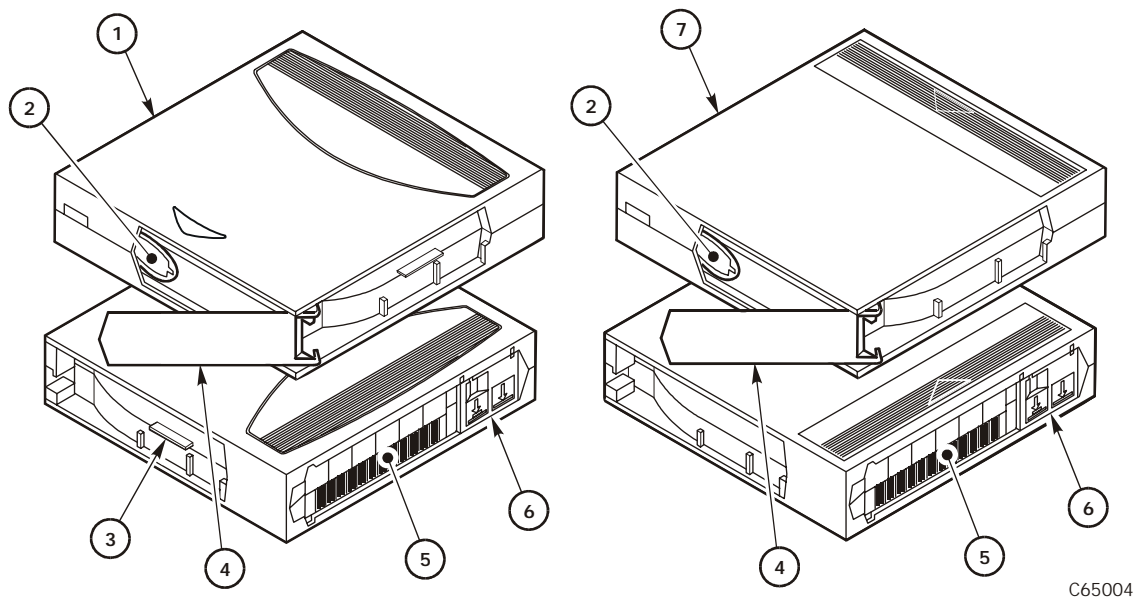

1. SDLT cartridge
2. Tape leader
3. SDLT cartridge identifier tab
4. Access door
5. Volume serial number (VOLSER) label
6. Read/Write-protect switch
7. DLT cartridge

Figure A-2. 9840/T9840B Cartridge Components (C65007)

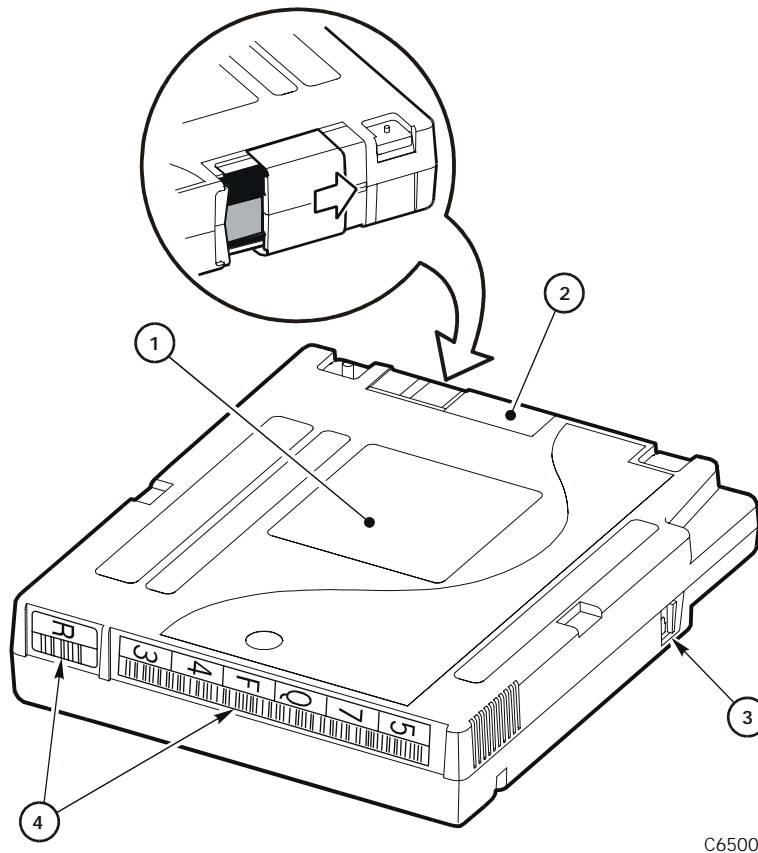

C65007

1. Customer label
2. Access door
3. Write-protect switch
4. Volume label and media type labels (Media: "R" = data, "U" = cleaning)

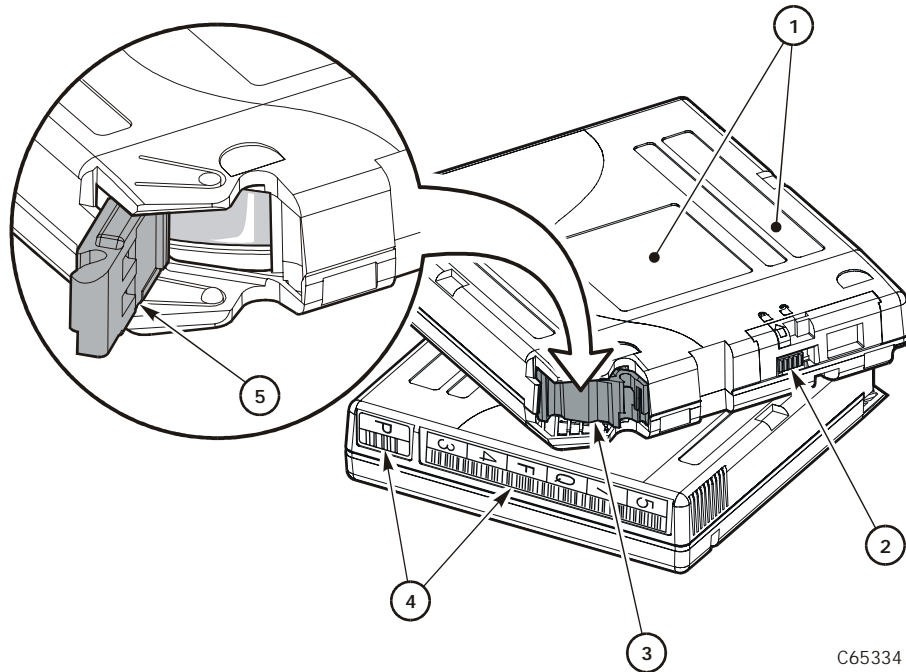
Figure A-3. T9940 Cartridge Components (C65334)

1. Customer and manufacturer's labels
2. Write protect switch
3. Access door (leader block—closed)
4. VOLID and media labels (Media label: "P" = data, "W" = cleaning)
5. Access door (leader block—open)

Figure A-4. Ultrium Cartridge Components (C65303)

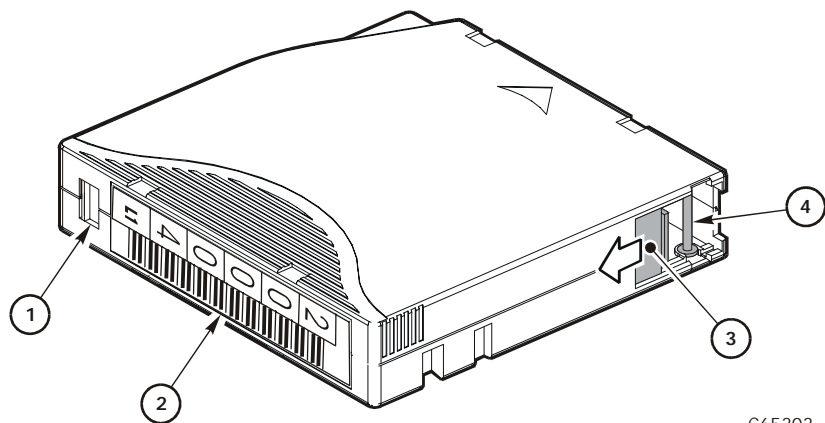

C65303

1. Write-protect switch (Data Cartridge = red, Cleaning Cartridge = gray)
2. Volume serial number (VOLSER)
3. Access door
4. Leader pin

Table A-3. Ultrium Cartridge Codes

Label	Type of Cartridge
L	Data cartridge
C ₁ plus CLN	Cleaning cartridge for Hewlett Packard
C ₃ plus CLN	Cleaning cartridge for Seagate
L plus DG	Diagnostic cartridge (apply a DG label to a blank data cartridge to be used for diagnostic tests)

Table A-4. Ultrium Cartridge Models

Description	Model Number
Ultrium media cartridge	MEDLTOM
Required feature code:	
20-count 100 GB data cartridges	1C20
EDP Vivid Color Labels	EVLA
Horizontal labels	HLBL
Vertical labels	VLBL

Use the URL below to order cartridges.

Ordering Tape Cartridges/Labels

The Media Service Center in Atlanta handles orders for cartridge tapes and labels. To obtain additional information about cartridge tapes and labels call the Media Service Center at 1-800-905-8502, or fax 1-877-888-0609; from 8 a.m. to 8 p.m. United States Eastern Standard Time, Monday Through Friday. You may also find information on cartridges and labels at the following Web site:

<http://storagetek.com/products/tape/services/>

Order cartridge tapes and labels by including the order on the sales entry form, if used; the media portion of the order will be routed to the appropriate department.

Orders for domestic customers, value-added distributors (VADs), and value-added resellers (VARs):

Media Service Center
 5390 Triangle Parkway, Suite 300
 Norcross, GA 30092
 Voice: 1-800-905-8502
 Fax: 1-877-888-0609

Orders from distributors, original equipment manufacturers (OEMs), and Canada, Japan, Australia, South Asia, or Mexico subsidiaries:

Orders Management
 One StorageTek Drive
 Louisville, CO 80028-4350
 Voice: 303-673-5513:
 Fax: 303-673-2640 for distributors or subsidiaries
 Fax: 303-673-7654 for OEM

■ Applying Cartridge Labels to DLT Cartridges

Cartridge labels reflect the cartridge media and usage. The letter located next to the last number in the volume label reflects the media. Cleaning cartridges have “CLN” in the volume label, diagnostic cartridges have “DG” in the volume label.

The kinds of cartridge labels you might need to apply are:

- CompacTape III volume label
- CompacTape IIIXT volume label
- CompacTape IV volume label
- Diagnostic cartridge volume label
- Cleaning cartridge volume label

Refer to [Figure A-5](#) and insert the label into the recessed area provided on each cartridge:

1. Make sure the cartridge has been at room temperature for at least 24 hours.
2. Clean the surface where the labels will be placed using a cleaning solution made for this purpose. Refer to [“Cartridge Exterior—Cleaning” on page A-22](#).
3. Locate the label that you require and refer to [Figure A-5](#):
 - CompacTape III has a “C” next to the far left number, bar code down.
 - CompacTape IIIXT has an “E” next to the far left number, bar code down.
 - CompacTape IV has a “D” next to the far left number, bar code down.
 - Diagnostic cartridge has “DG” at the beginning of the volume label.
 - Cleaning cartridge has “CLN” at the beginning of the volume label.
4. Hold the cartridge so the write-protect switch is toward you.
5. Refer to [Figure A-5 on page A-11](#) and slide the label under the slots in the recessed area. If you prefer, peel the backing from the label and then slide it under the slots, pressing it into place.

Notes:

1. Make sure the labels are not placed elsewhere on the cartridge surface.
2. Make sure the edges of the labels do not curl; curling causes the cartridge to stick in the drive loader and the robot will misread the volume label.
3. Use labels that do not leave a residue when removed.
4. Make sure the label contains a volume label and media letter.

Figure A-5. Applying Cartridge Labels to DLT and SDLT Cartridges (C65005)

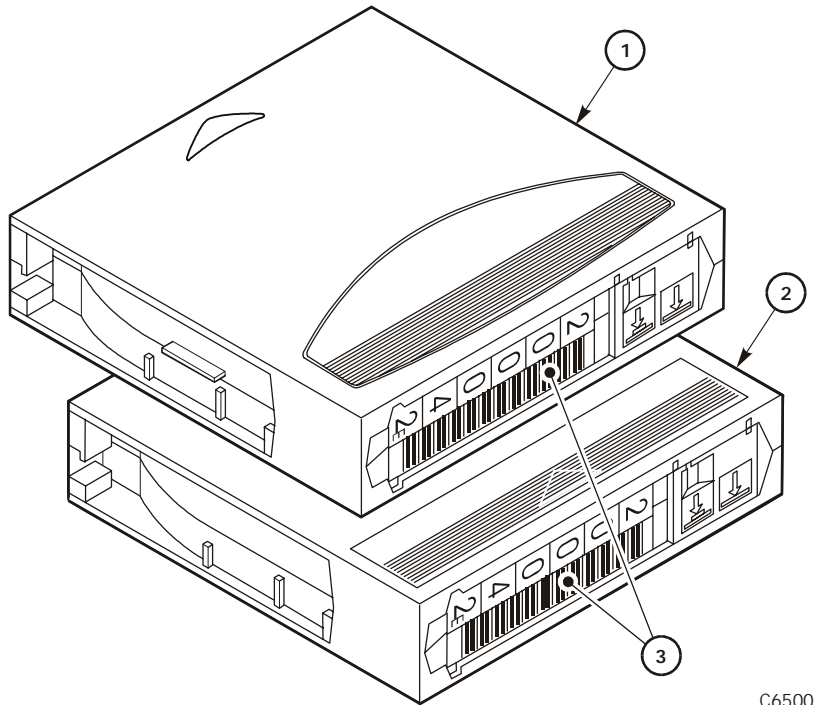

C65005

1. SDLT cartridge
 2. DLT cartridge
 3. Volume labels
-

■ Applying Cartridge Labels to 9840/T9840B Cartridges

Cartridge labels reflect the cartridge media and usage. The letter located next to the last number in the volume label reflects the media. Cleaning cartridges have “CLN” in the volume label, diagnostic cartridges have “DG” in the volume label.

Figure A-6. Applying Cartridge Labels to 9840/T9840B Cartridges (C65008)

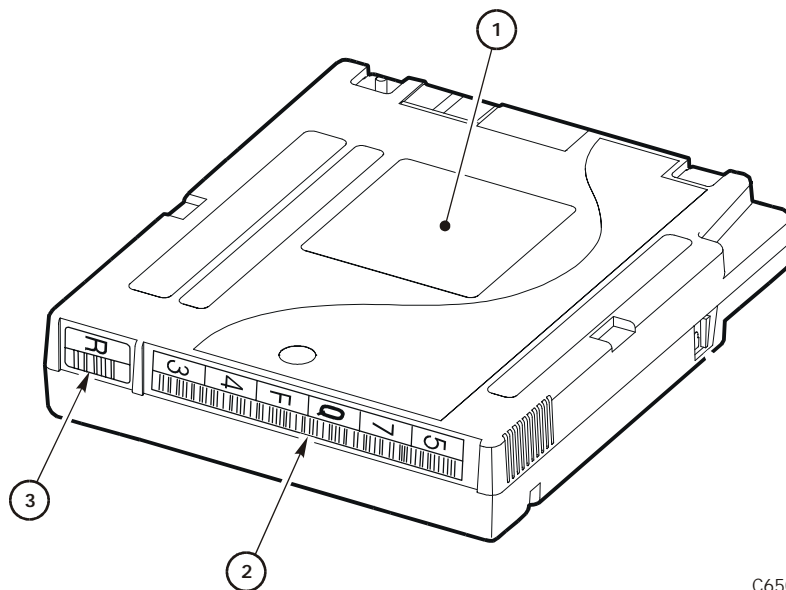

1. Customer label
 2. Volume label
 3. Media ID label (“R” = data, “U” = cleaning)
-

■ Applying Cartridge Labels to T9940 Cartridges

Cartridge labels reflect the cartridge media and usage. The letter located next to the last number in the volume label reflects the media. Cleaning cartridges have “CLN” in the volume label, diagnostic cartridges have “DG” in the volume label.

Figure A-7. Applying Cartridge Labels to T9940 Cartridges (C65335)

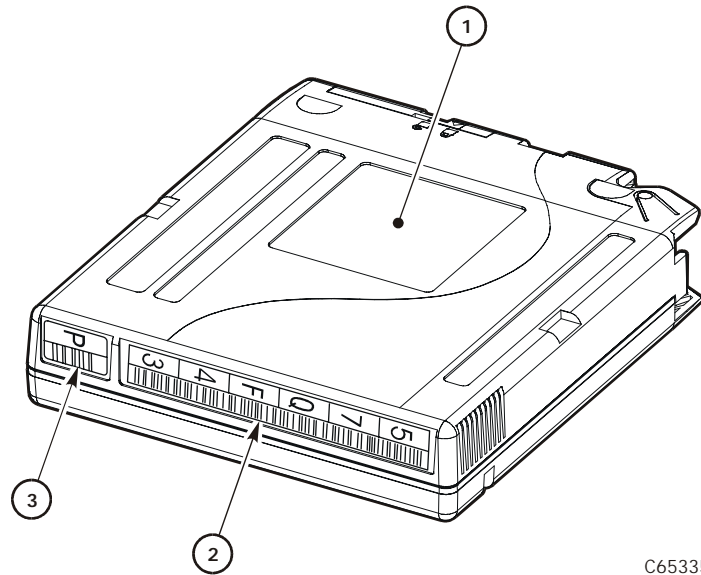

C65335

1. Customer label
 2. Volume label
 3. Media ID label ("P" = data, "W" = cleaning)
-

■ Applying Cartridge Labels to Ultrium Cartridges

Cartridge labels reflect the cartridge media and usage. The letter located next to the last number in the volume label reflects the media. Cleaning cartridges must match the drive type (see note below); diagnostic cartridges have “DG” in the volume label.

Figure A-8. Ultrium Cartridge Label (C65304)

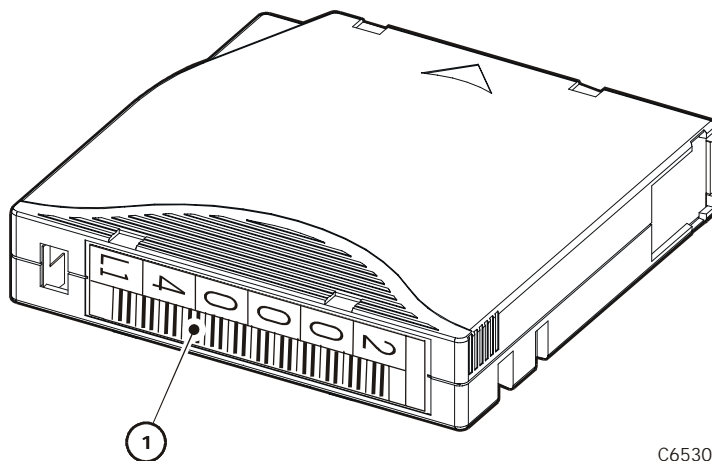

C65304

Note: For cleaning cartridges, you must have a cartridge and label that matches the drive type:

1. Label location:
 - For Hewlett-Packard Ultrium cleaning cartridges, the prefix is CLNH
 - For IBM Ultrium cleaning cartridges, the prefix is CLNI
 - For Seagate Ultrium cleaning cartridges, the prefix is CLNS
- See [Table A-3 on page A-8](#) for label codes.

■ Setting the DLT and SDLT Write-protect Switch

As shown in [Figure A-9](#), you can set the write-protect switch so the cartridge is *write-enabled*. Slide the switch to the right so the orange indicator is not visible. In this position, the drive can write as well as read data. This setting is recommended when inserting cartridges into the tape library.

You can set the write-protect switch so that the cartridge is *read-only* (nothing can be written on the tape). Slide the switch to the left so that the orange indicator is visible. In this position, the drive can only read data from the tape, but cannot write data on it.

Figure A-9. Setting the DLT and SDLT Write-protect Switch (C65006)

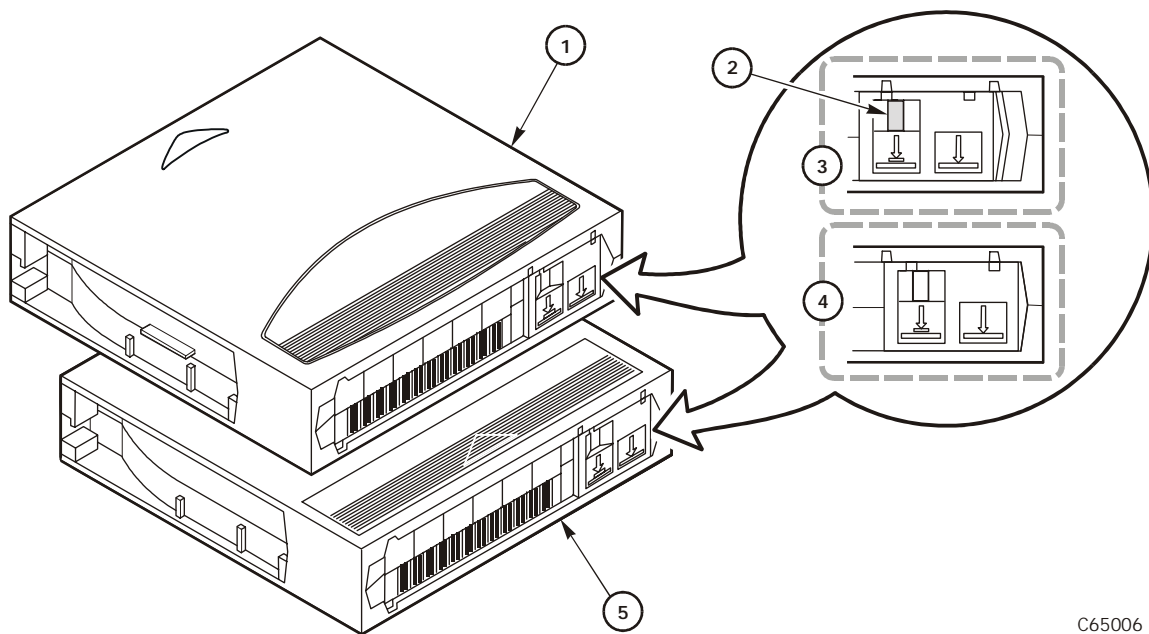

C65006

1. SDLT cartridge
2. Orange indicator
3. Write-protect position
4. Write-enabled position
5. DLT cartridge

■ Setting the 9840/T9840B Write-protect Switch

As shown in [Figure A-10](#), you can set the write-protect switch so the cartridge is *write-enabled*. Slide the switch to the left to write-enable the tapes. In this position, the drive can write as well as read data. This setting is recommended when inserting cartridges into the tape library.

You can set the write-protect switch so that the cartridge is *read-only* (nothing can be written on the tape). Slide the switch to the right. In this position, the drive can only read data from the tape, but cannot write data to it.

Figure A-10. Setting the 9840/T9840B Write-protect Switch (C65009)

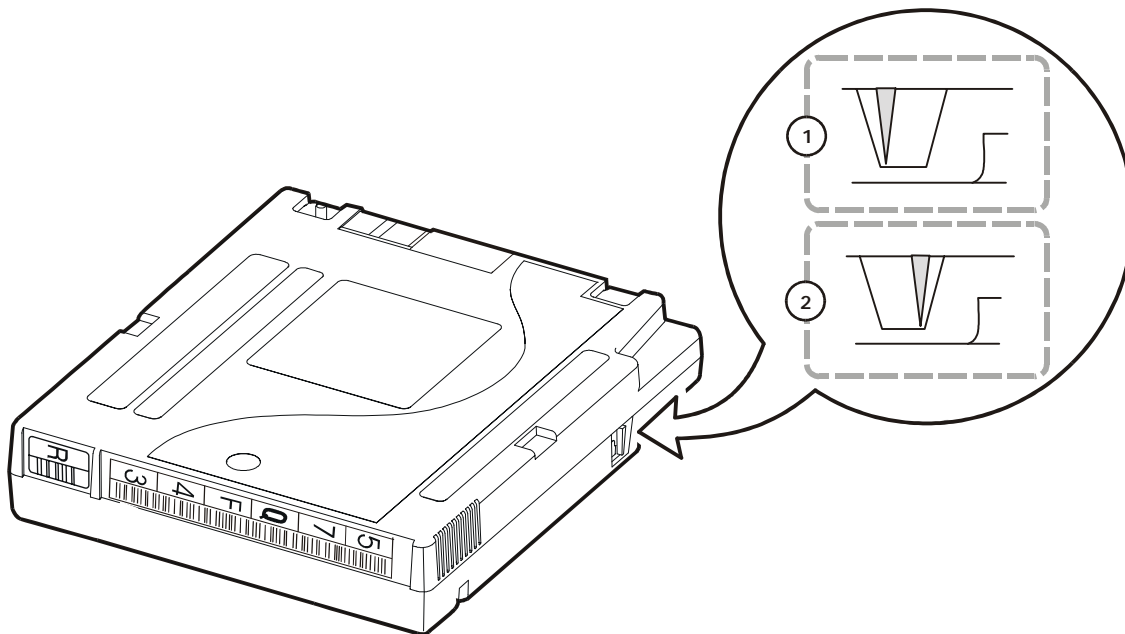

C65009

1. Write-enabled position
 2. Write-protect position
-

■ Setting the T9940 Write-protect Switch

As shown in [Figure A-11](#), you can set the write-protect switch so the cartridge is *write-enabled*. Slide the switch to the right to write-enable the tapes. In this position, the drive can write as well as read data. This setting is recommended when inserting cartridges into the tape library.

You can set the write-protect switch so that the cartridge is *read-only* (nothing can be written on the tape). Slide the switch to the left. In this position, the drive can only read data from the tape, but cannot write data to it.

Figure A-11. Setting the T9940 Write-protect Switch (C65336)

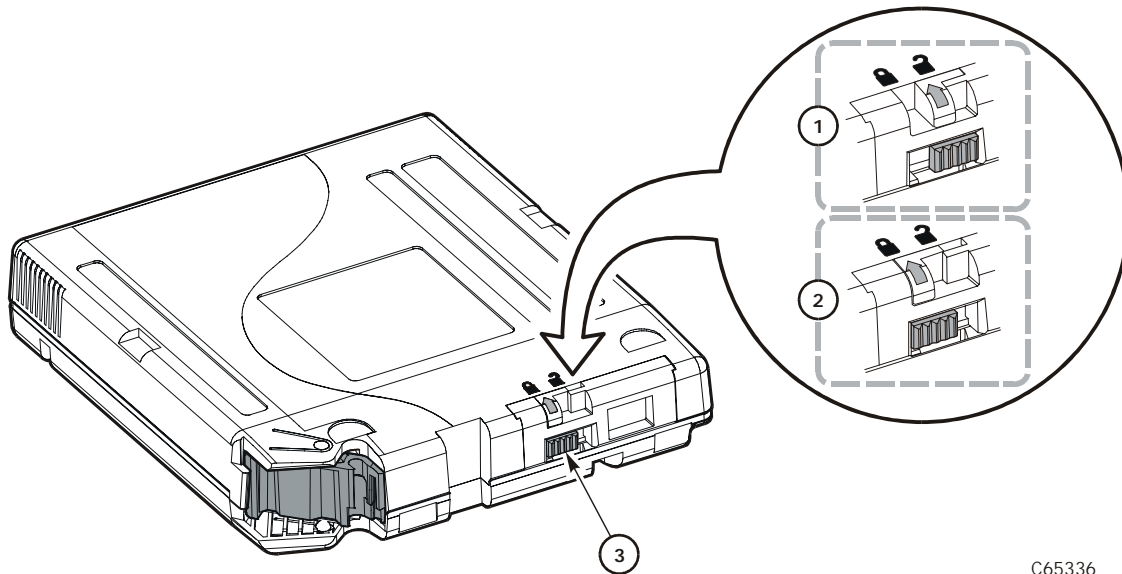

C65336

1. Write-enabled position
2. Write-protect position
3. Write-protect switch

■ Setting the Ultrium Write-protect Switch

As shown in [Figure A-12](#), you can set the write-protect switch so the cartridge is *write-enabled*. Slide the switch to reveal the “open lock” symbol to write-enable the tapes. In this position, the drive can write as well as read data. This setting is recommended when inserting cartridges into the tape library.

You can set the write-protect switch so that the cartridge is *read-only* (nothing can be written on the tape). Slide the switch to reveal the “closed lock” symbol. In this position, the drive can only read data from the tape, but cannot write data to it.

Figure A-12. Setting the Ultrium Write-protect Switch (C65305)

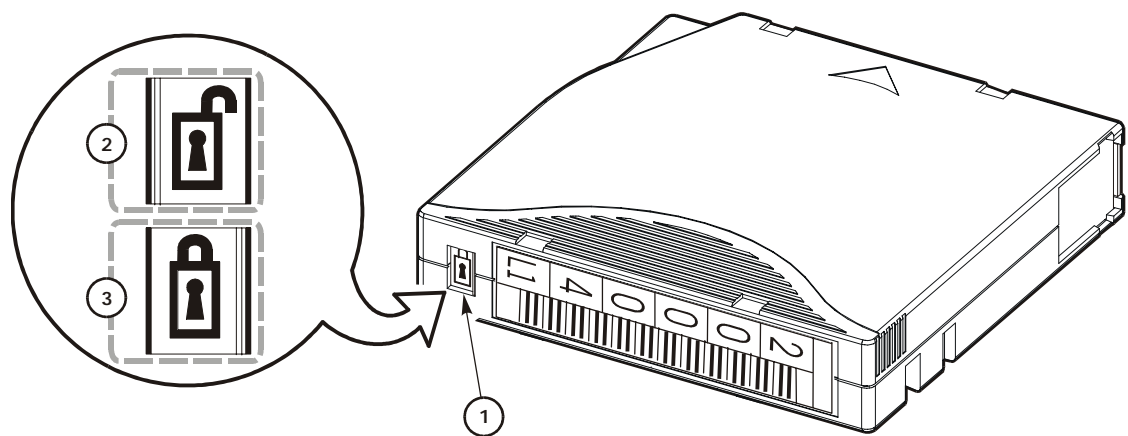

C65305

1. Write-protect switch (Data Cartridge = red, Cleaning Cartridge = gray)
2. Write-enabled
3. Write-protected

■ Maintaining Cartridges

The following pages list cartridge environmental specifications, describe how to store and clean cartridges, use cleaning cartridges, and repair a detached leader block.

DLT Cartridge Environmental Specifications

The following specifications refer to the operating and storage environments for DLT cartridges.

Table A-5. DLT Cartridge Environmental Specifications

Operating environment

Temperature	10° to 40°C (50° to 104°F)
Relative humidity	20% to 80% noncondensing
Wet-bulb temperature	25°C (77°F) maximum

CAUTION:

Potential cartridge damage: Tape temperatures above 49°C (120°F) might damage the tapes. If during storage or transportation a cartridge has been exposed to conditions exceeding the above values, before using the cartridge, keep the cartridge within those operating environment specifications for at least as long as the time that the cartridge exceeded the specifications, up to two hours. Make sure that the cartridge has no moisture on it.

When storing DLT cartridges, the stray magnetic field at any point on the tape shall not exceed 4000A/m. Make sure that the cartridge has no moisture on it.

Cartridge storage environment

Temperature	16° to 32°C (61° to 90°F)
Relative humidity	20% to 80% non condensing
Wet-bulb temperature	26°C (79°F) maximum

Cartridge storage environment for cartridges intended for archiving data for one year or more

Temperature	18° to 26°C (64° to 79°F)
Relative humidity	20% to 60%

For more information on DLT cartridges, visit the Quantum web site at

<http://www.quantum.com>

9840/T9840B Cartridge Environmental Specifications

The following specifications refer to the operating and storage environments for 9840/T9840B cartridges.

Table A-6. 9840/T9840B Cartridge Environmental Specifications

<i>Operating environment</i> ¹	
Temperature	15.6° to 32.2°C (60° to 90°F)
Relative humidity	20% to 80%
Wet-bulb temperature	26°C (78.8°F) maximum
<i>Cartridge storage environment (archive)</i>	
Temperature	5° to 25.5°C (41° to 78°F)
Relative humidity	40% to 60%
Wet-bulb temperature	26°C (78.8°F) maximum
<i>Cartridge storage environment (non-archive)</i>	
Temperature	5° to 32.2°C (41° to 90°F)
Relative humidity	5% to 80%
Wet-bulb temperature	26°C (78.8°F) maximum
<i>Cartridge shipping environment (unrecorded)</i> ²	
Temperature	-23° to 49°C (-10° to 120°F)
Relative humidity	5% to 80%
Wet-bulb temperature	26°C (78.8°F) maximum
<i>Cartridge shipping environment (recorded)</i> ²	
Temperature	4° to 40°C (40° to 104°F)
Relative humidity	5% to 80%
Wet-bulb temperature	26°C (78.8°F) maximum

Notes: 1. The conditioning time before use is 24 hours.

2. The shipping environment must not exceed the limit of the storage environment, archive or non-archive, for longer than 10 days.

Ultrium Cartridge Environmental Specifications

The following specifications refer to the operating and storage environments for Ultrium cartridges.

Table A-7. LTO Ultrium Cartridge Environmental Specifications

<i>Operating environment</i> ¹ .	
Temperature	10° to 45°C (50° to 113°F)
Relative humidity	20% to 80%
Wet-bulb temperature	26°C (78.8°F) maximum
<i>Cartridge storage environment (archive)</i> ² .	
Temperature	16° to 25°C (61° to 77°F)
Relative humidity	20% to 50%
Wet-bulb temperature	26°C (78.8°F) maximum
<i>Cartridge storage environment (non-archive)</i>	
Temperature	16° to 32°C (61° to 90°F)
Relative humidity	20% to 80%
Wet-bulb temperature	26°C (78.8°F) maximum
<i>Cartridge shipping environment (unrecorded)</i> ³ .	
Temperature	-23° to 49°C (-10° to 120°F)
Relative humidity	20% to 80%
Wet-bulb temperature	26°C (78.8°F) maximum

Notes:

¹The conditioning time before use is 24 hours.

²Archival storage is one to 10 years.

³The shipping environment must not exceed the limit of the storage environment, archive or non-archive, for longer than 10 days.

Storage of Cartridges

When you store a cartridge:

- Leave it in its protective wrapping until you are ready to use it.
- Choose a clean environment that duplicates the conditions of the room in which it is used.
- Make sure it has been in its operating environment for at least 24 hours.

Cartridge Exterior—Cleaning

CAUTION:

Potential cartridge damage: Do not use certain solvents to remove labels or to clean cartridges because they can damage the cartridges. Do not use acetone, trichloroethane, toluene, xylene, benzene, ketone, methylethyl ketone, methylene chloride, ethyldichloride, esters, ethyl acetate, or similar chemicals.

Wipe all dust, dirt, and moisture from the cartridge with a lint-free cloth.

Use StorageTek Tape Cleaner Wipes, PN 4046289-01, to clean the cartridges. These wipes are saturated with isopropyl alcohol. Do not let any solution touch the tape or get inside the cartridge.

Repair of a Detached Leader Block

When a tape is damaged, use a backup tape. If a leader block is detached, there is no obvious damage to the cartridge or tape, and you have no backup tape, you may repair the leader block using a repair kit provided by your supplier. You can use the tape once to copy the data onto another tape.

Library Elements and Diagrams

B

This appendix provides wall diagrams of the tape library elements for all L700 models. It also contains an illustration of the MPC logic card and an overall diagram of the library.

The wall diagrams depict the SCSI element locations for all cell locations. The locations are noted at the top of the columns in hexadecimal (denoted by the “h” at the end of the number) and decimal.

The drive types and locations will vary with your tape library options. Each drive column displaces 60 cell locations.

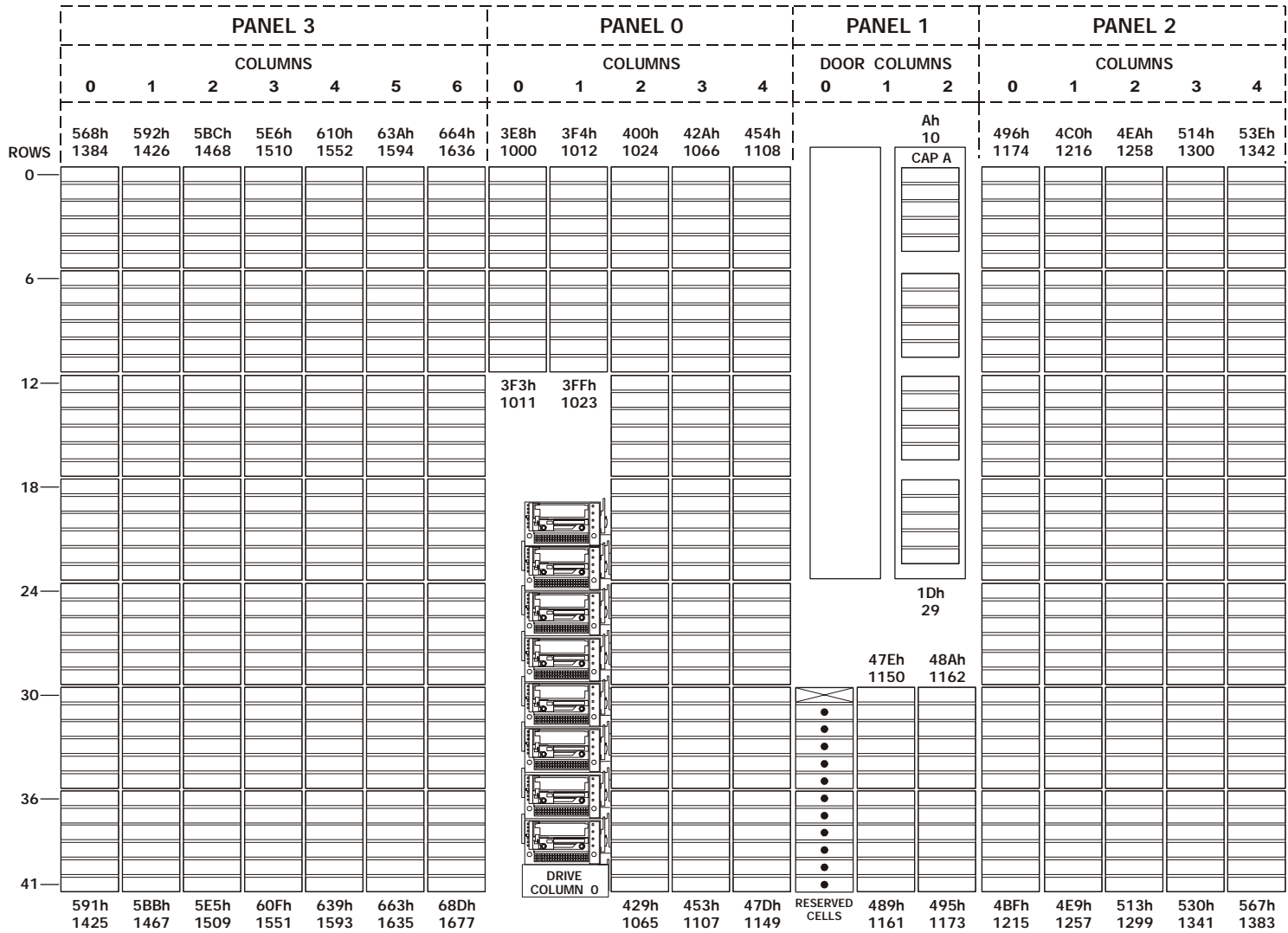

C65048

Figure B-1. Tape Library Elements—1 CAP, 1 Drive Column (C65048)

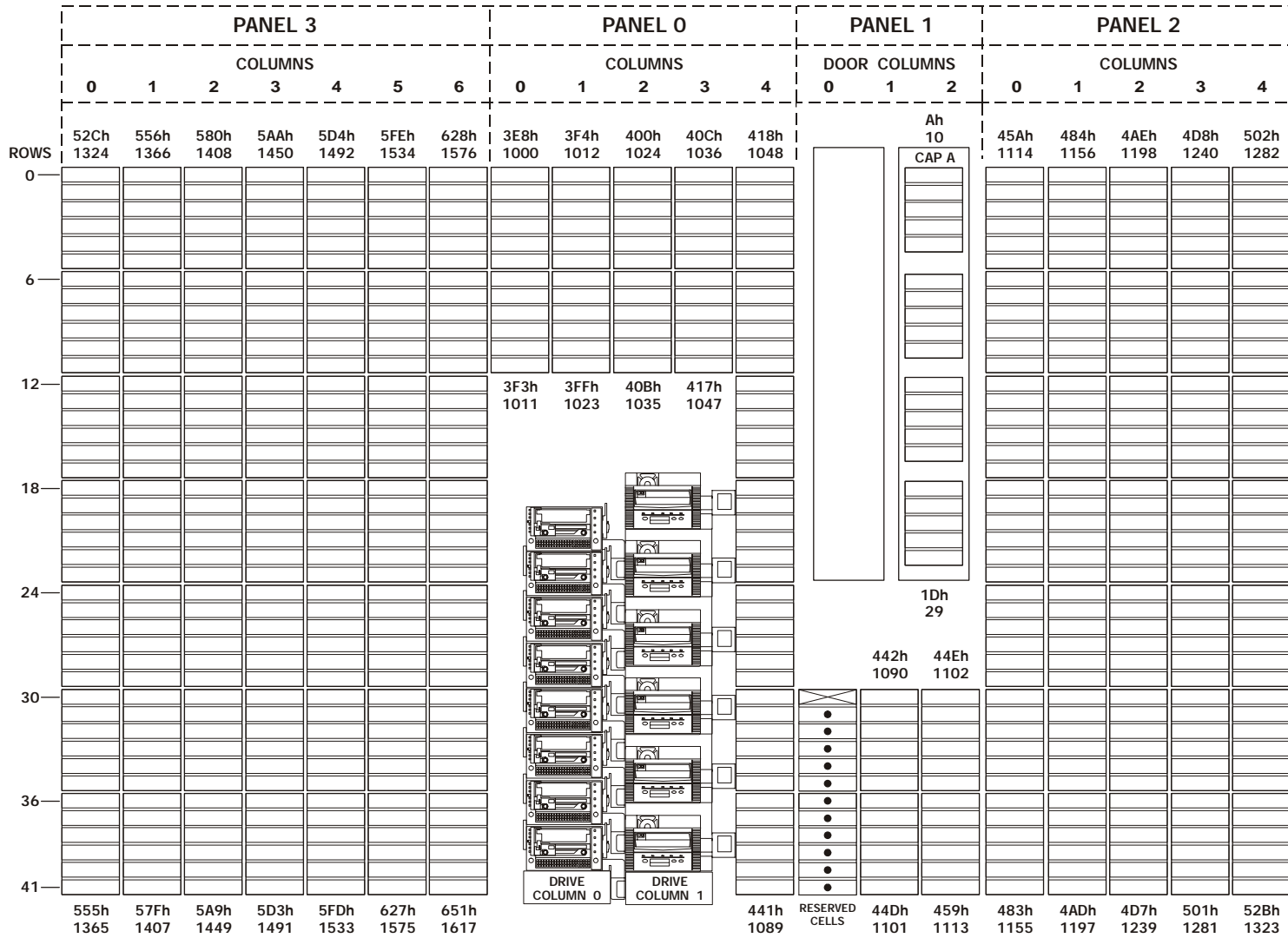

C65049

Figure B-2. Tape Library Elements—1 CAP, 2 Drive Columns (C65049)

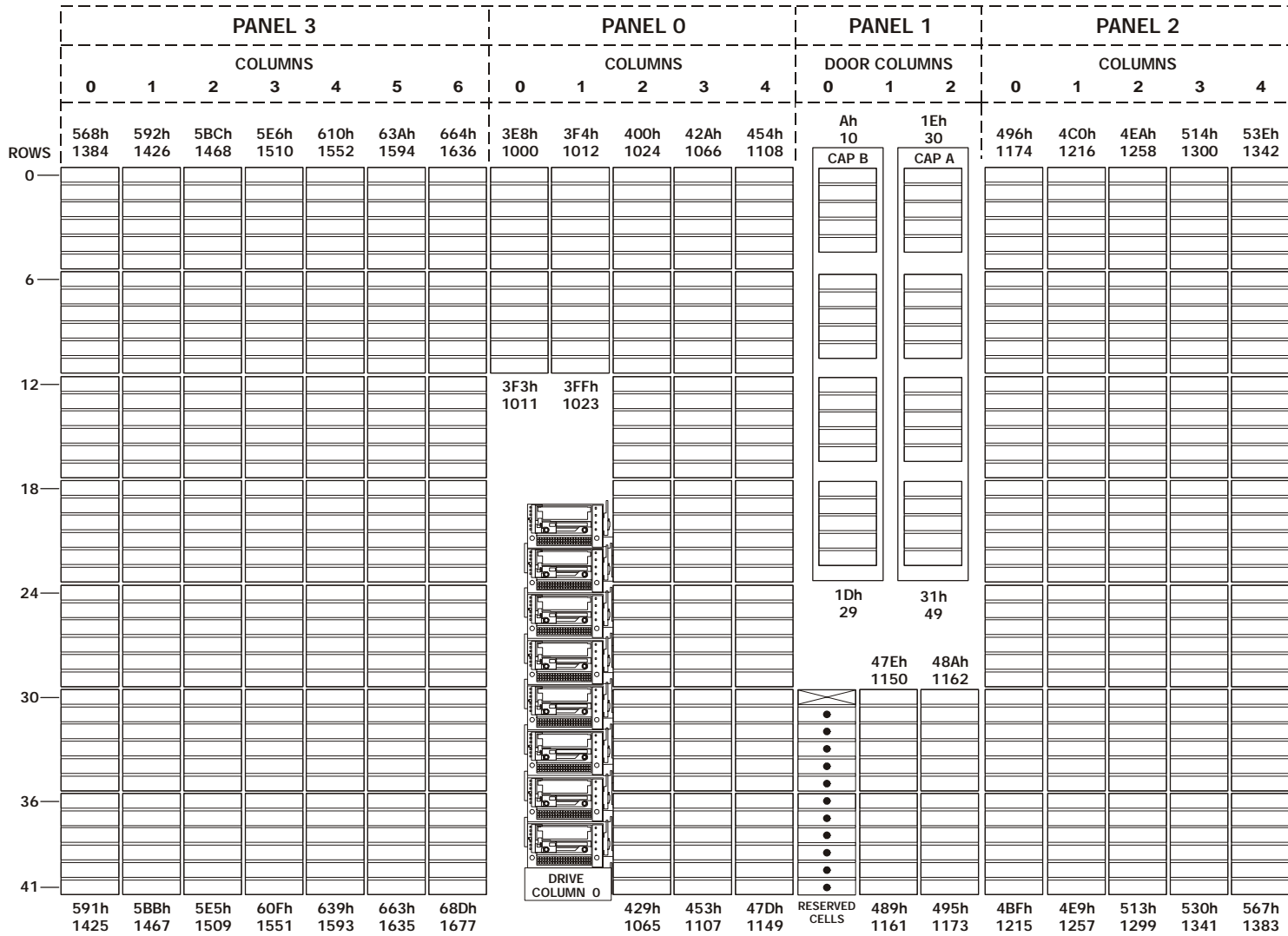

C65050

Figure B-3. Tape Library Elements—2 CAPs, 1 Drive Column (C65050)

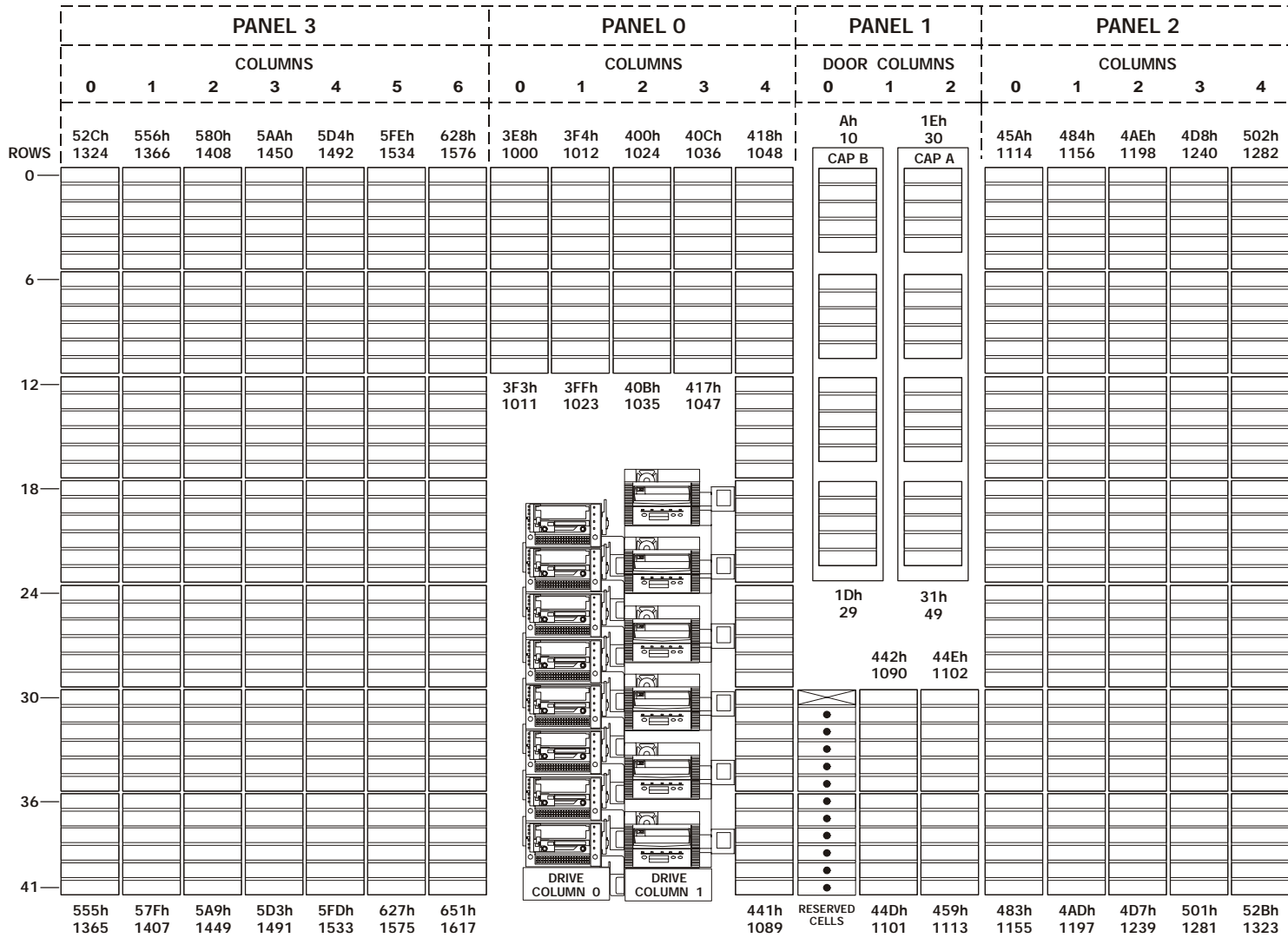

C65051

Figure B-4. Tape Library Elements—2 CAPs, 2 Drive Columns (C65051)

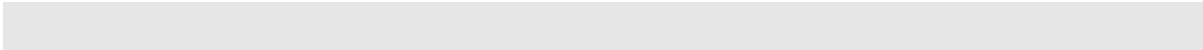

This page intentionally left blank.

Glossary

This glossary defines abbreviations and new or special terms in this publication.

Some of the definitions are taken from the *IBM Dictionary of Computing*. The letters in the parentheses that follow some definitions indicate the source of the definition:

(A) *The American National Standard Dictionary for Information Systems*, ANSI X3.172-1990, copyright 1990 by the American National Standards Institute (ANSI).

(E) The ANSI/Electronic Industries Association (EIA) Standard-440-A, *Fiber Optic Terminology*.

(I) *The Information Technology Vocabulary*, developed by Subcommittee 1, Joint Technical Committee 1, of the International Organization for Standardization and International Electrotechnical Commission (ISO/IEC/JTC1/SC1).

(IBM) *The IBM Dictionary of Computing*, copyright 1994 by IBM.

(T) Draft international standards committee drafts, and working papers being developed by the ISO/IEC/JTC1/SC1. This glossary defines abbreviations and new or special terms in this publication.

A

Automated Cartridge System Library Software (ACSL) The software within a Unix-based server that interfaces the server and hosts; it also maintains a list of all tapes within a library.

Advanced Interactive Executive (AIX) The operating software for an IBM RISC System/6000.

audit • A part of the tape library IPL sequence that catalogs all tape cartridge

locations. This data is retained in the MPC card memory.

Host audit—A host request to catalog the tape cartridges of a tape library by SCSI element or tape library number, panel, row, column.

automatic mode A relationship between a tape library and all attached hosts. Tape libraries operating in automatic mode handle cartridges without operator intervention. This is the normal operating mode of a tape library that has been placed online to all host CPUs.

B

backward read compatible (BRC) The ability of a tape drive to read data forward or backward. *Contrast with* “NBRC” (below).

C

CAP *See* cartridge access port.

cartridge The plastic housing around a cartridge tape. A plastic leader block is attached to the tape for automatic threading when loaded in a transport. The spine of the cartridge contains a Tri-Optic label listing the volume identification number.

cartridge access port (CAP) An assembly allowing an operator to enter or eject cartridges during automated operations.

cartridge drive A device that reads from or writes to a magnetic tape.

cartridge tape Magnetic tape enclosed in a plastic housing.

catalog The inventory of all tape cartridge storage locations in an L700 tape library; this

inventory is by SCSI element or tape library number, panel, row, column.

cell A slot in the tape library that is used to store a tape cartridge.

Customer Support Services StorageTek's service representative organization. Customers with Storagetek maintenance contracts may contact this center 24 hours a day, seven days a week.

Customer Resource Center StorageTek's Web-based service that provides technical information to customers with StorageTek maintenance contracts. A log-in and password are required.

configuration The physical description of a tape library, listing the panel types, cartridge capacity, type of host connection, and number of tape drives.

customer services *See* Central Support Services.

D

DHCP *See* dynamic host configuration protocol.

diagnostic tests Tests, accessible through the tape library Operator Panel or LibConnect interface, that allow a local user to run offline tests within the tape library.

dynamic host configuration protocol (DHCP) Server software that, when enabled, sets the library IP address, subnet mask, and name.

E

electronically erasable programmable read-only memory (EEPROM) A memory component that can be erased and programmed while the component is left in the machine.

event examination A file accessible through the operator panel, that contains

events that occurred during the functional operation of the tape library. *See* fault symptom code.

F

fault symptom code (FSC) Error or information code generated by functional or diagnostic software that may directly or indirectly be used to indicate the field replaceable unit (FRU) that is probably causing the error.

field replaceable unit (FRU) Assembly that is replaced in its entirety when any one of its components fails.

H

Horizon L Series Library Monitor An optional web-based interface that monitors library activity and allows modification of the library configuration.

I

initial program load (IPL) A process that activates a machine reset and loads system programs to prepare a computer system for operation. Processors having diagnostic programs activate these programs at IPL execution.

in-transit cartridges Cartridges that have been moved from their home cell by the robot. The host software must recover these cartridges to a known location to clear out the software in-transit record.

in-transit record A temporary record written by the host software, noting that a cartridge has been moved from its home cell. Once this cartridge is returned to its home cell, the record is erased.

L

LTO Linear Tape-Open, an open

specification for tape storage devices.

M

manual mode A relationship between an tape library and all attached hosts. Tape libraries operating in manual mode have been placed offline to all host CPUs and require human assistance to perform cartridge operations.

media format Format of data written on tape (36 track, compressed, etc.)

MPU card The Fibre (PCI) expansion card for the tape library).

MPC card The central processing unit card for the tape library.

MPF card The DC power supply card for the tape library.

N

non-backward read compatibility (NBRC) A tape drive that can only read data forward. *Contrast with* "BRC" (above).

non-maskable interrupt (NMI) An interrupt that cannot be shut off by executing a disable interrupt instruction on the microprocessor. These interrupts are principally reserved for fatal conditions (for example, parity errors, watchdog timer faults).

O

offline Not available for functional use by the host CPU.

online State of being controlled directly by or in direct communication with a computer. Available for functional use.

R

recoverable error Error condition that can be automatically corrected (for example, by initiating a retry operation) and, when corrected, allows continuous processing of a job, program, or hardware function.

remote center StorageTek's customer services organization. Customers with Storagetek maintenance contracts may contact this center 24 hours a day, seven days a week.

reset button This button will start a initial microprogram load to the library.

robot Electro-mechanical device for locating and moving cartridges.

S

servo Device that uses closed-loop feedback to govern physical positioning.

small computer systems interface (SCSI) A type of data or control interface between the tape library/ tape drives and host.

T

theta motor The motor responsible for the lateral movement of the hand mechanism in the tape library.

Tri-Optic label An external label attached to the spine of a cartridge that is both human and machine readable.

U

Ultrium The single hub implementation of the LTO specification for tape storage devices.

unrecoverable error Error condition that cannot be automatically corrected and that requires external intervention for possible correction. It causes termination of a job, program, or hardware function.

UPS Uninterruptable Power Source: A switching device to enable battery backup power when the site power source fails.

V

volume serial label (VOLSER) An alphanumeric label used by host software to

identify a volume (sometimes used to indicate the contents of a tape).

volume Magnetic tape cartridge.

Z

Z-column The column that allows the hand mechanism in the tape library to move vertically.

Index

Numerics

- 3580. *See* IBM Ultrium
- 9840/T9840B
 - cartridge environmental specifications, A-20
 - cartridge inspection, A-6
 - cartridge label placement, A-12
 - Fibre Channel address, 3-11
 - loading a cartridge, 4-31
 - unloading a cartridge, 4-32
 - write-protect switch, A-16, A-17
- 9940. *See* T9940

A

- access, 4-23
- ACSLs
 - addressing rules, 3-5
- agreement, internal code, xix
- alert messages in manual, xiv
- applying cartridge labels, A-10
- auto clean, definition, 1-13
- auto cleaning
 - cartridge life, 3-16
 - described, 3-16
- automated mode
 - definition of, 1-13
 - operating in, 4-1

C

- CAP
 - entering DLT cartridge, 4-13
 - magazine, illustrated, 4-12
- CAP (cartridge access port)
 - description, 1-10
 - exporting cartridges, 4-14, 4-16
 - importing cartridges, 4-11
 - magazine numbering, 4-5
 - magazine retention covers, 4-10
- CAP information screen, 2-7
- capacity, tape library, 1-6
- cartridge
 - loading into 9840/T9840B, 4-31
 - loading into IBM Ultrium, 4-33
 - loading into T9940B, 4-31
 - unloading from 9840/T9840B, 4-32
 - unloading from DLT, 4-30
 - unloading from T9940B, 4-32
- cartridge access port. *See* CAP
- cartridges
 - colored, A-4
 - exporting through CAP, 4-14, 4-16
 - importing through CAP, 4-11
 - label, A-11
 - labels
 - ordering information, A-3
 - loading into arrays, 3-18
 - loading into DLT, 4-28
 - locating manually, 4-25
 - maintenance, A-19
 - ordering information, A-3 (DLT/SDLT), A-1
 - repairing leader block, A-22
 - starter kits, A-2
 - storing, A-22
- caution
 - messages in manual, xiv
 - rack limitations, xxiv
 - shielded cables, xvii
 - static electricity, -xxvi
- caution notices
 - DLT cartridge moisture, A-19
 - DLT cartridge temperature, A-19
 - removing cartridge from hand, 4-26
 - retracting gripper, 4-27
 - retracting reach mechanism, 4-24
- caution, description of, xiv
- CE compliance statement, xvii
- cell
 - capacity, 1-6
 - storage, 1-5
- clean, auto feature, 1-13
- clean, manual clean of drive, 4-16
- cleaning cartridge exterior, A-22
- cleaning cartridge, label, A-10
- cleaning cartridges

- DLT
 - part numbers, A-3
- DLT/DLT1
 - starter kit, A-2
- Ultrium
 - part numbers, A-3
 - starter kit, A-2
- colored cartridges, A-4
- CompacTape labels, A-11
- compliance statements
 - CE, xvii
 - FCC, xvii
 - Japanese, -xviii
 - Taiwan, -xviii
- components, tape library
 - cartridge access port, 1-10
 - drives, 1-11
 - robot, 1-3
 - storage cells, 1-5
- configuration
 - cleaning cartridge life, 3-16
 - Fibre Channel port address, 3-5
 - operator panel entry, 3-4
- contacting StorageTek, 5-1
- controlling software, 1-12
- conventions in manual, xiv
- Customer Initiated Maintenance (CIM), 5-1
- customer label, A-10
- Customer Resource Center (CRC), xv
- Customer Support Services (CSS), 5-1

D

- data
 - cartridges
 - part numbers, A-3
- diagnostic cartridge label, A-10
- diagnostic cartridges
 - DLT
 - part numbers, A-3
 - DLT/DLT1
 - starter kit, A-2
 - Ultrium
 - part numbers, A-3
 - starter kit, A-2
- diagnostics screen, 2-10
- digital linear tape. *See* DLT
- display, 2-1

- display. *See also* operator panel
- DLT
 - cartridge environmental specifications, A-19
 - cartridge labels, A-10
 - entering a cartridge, 4-13
 - loading a cartridge, 4-28
 - unloading a cartridge, 4-30
 - write-protect switch, A-15
- doors, opening, 4-22
- drive configuration screen, 2-14
- drive information screen, 2-8
- drives
 - 9840, 1-11
 - configuration screen, explained, 3-10
 - DLT, 1-11
 - information on operator panel, 4-4
 - numbering, internal, 3-10
 - power switch, 2-21

E

- elements
 - L700
 - 1 CAP, 1 drive column, B-2
 - 1 CAP, 2 drive columns, B-3
 - 2 CAPs, 1 drive column, B-4
 - 2 CAPs, 2 drive columns, B-5
- entering cartridges through CAP
 - 9840, 4-14
 - DLT, 4-13
 - general procedure description, 4-16
 - Ultrium, 4-15
- e-Partners web site, xvi
- error log. *See* event log screen.
- ESD prevention, xxvi
- Ethernet address, viewing the, 3-12
- event log screen, 2-6
- expansion frame, 1-5
- exporting cartridges through CAP, 4-14, 4-16

F

- fast load, option, 3-7
- FCC compliance statement, xvii
- features
 - auto clean, 1-13
 - safety, 1-12

- fiber-optic cables
 - connectors, xxiii
 - handling, xxii
 - installation, xxii
- Fibre Channel
 - 9840/T9840B address, 3-11
 - configuration menu (library), 2-13
 - library address, 3-6
 - port address, 3-5
 - worldwide IDs (library), 3-6
- firmware
 - cleaning cartridge life, 3-16
- G**
- gripper mechanism location, 4-27
- H**
- hand
 - description of, 1-3
 - removing cartridge from, 4-26
 - See also* robot.
- hand-camera, moving, 4-24
- hardcopy publications from StorageTek, xvi
- Hewlett Packard. *See* HP Ultrium
- Horizon L Series Library Monitor
 - configuration, 3-9
- Horizon Library Monitor
 - configuration, 3-17
 - feature described, 1-12
 - Web password, 3-9
- host bus adapter (HBA)
 - address ranges, 3-4
- HP Ultrium
 - cartridge components, A-8
 - loading a cartridge, 4-33
 - write-protect switch, A-18
- I**
- IBM Ultrium
 - cartridge components, A-8
 - loading a cartridge, 4-33
 - write-protect switch, A-18
- importing cartridges through CAP, 4-11
- indicators, operator panel, 2-1
- information
 - ordering cartridge (DLT/SDLT) tapes, A-1
- initialization
 - defined, 3-3
 - restarting, 3-3
- installation
 - fiber-optic cables, xxii
- internal code license, xix
- IP address, setting the, 3-13
- IPL (initial program load) procedure, 3-2
- J**
- Japanese compliance statement, -xviii
- L**
- L700e Tape Library. *See* library
- label, laser product, xxi
- labels
 - Ultrium codes, A-8
 - Ultrium prefixes, A-8
- labels, applying, A-10
- laser product label, xxi
- leader block, repairing, A-22
- library
 - cleaning cartridge life, 3-16
 - Fibre Channel address, 3-6
- library components, tape
 - cartridge access port, 1-10
 - drives, 1-11
 - robot, 1-3
 - storage cells, 1-5
- library configuration screen, 2-12
- library name, setting the, 3-12
- library operating modes, 1-12
- library statistic screen, 2-6
- library status screen, 2-4
- library, tape
 - components, 1-1
 - configuration screen, 2-12
 - description of, 1-1
 - doors, opening, 4-22
 - Ethernet address, 3-12
 - IP address, 3-13
 - library name, 3-12
 - operator panel, 2-1
 - Port 0 address, 3-5

- power, 2-18
- safety, 1-12
- See also* operations.
- Web password, 3-9
- license, internal code, xix
- loading
 - 9840/T9840B cartridge, 4-31
 - IBM Ultrium cartridge, 4-33
 - T9940B cartridge, 4-31
- loading a cartridge
 - DLT drive, 4-28
- locating a cartridge manually, 4-25
- locations
 - CompacTape labels, A-11
 - DLT leader block, A-5
 - gripper mechanism, 4-27
 - reach mechanism, 4-26
 - VOLSER label, A-11
 - write protect switch, 9840, A-16, A-17
- log. *See* event log screen.
- LSM. *See* library

M

- magazine (cartridge)
 - removing, 4-12
 - retention cover, 1-10, 4-10
- maintenance, A-19
- manual mode
 - definition of, 1-13
 - operating in, 4-22
- menu, 2-5
- modes, library operating, 1-12

N

- network
 - configuration, 3-12
 - gateway address, 3-14
- notes, description of, xiv

O

- operating modes, library, 1-12
- operations
 - applying DLT cartridge labels, A-10

- automated, 4-1
- cleaning cartridge exterior, A-22
- exporting cartridges through
 - CAP, 4-14, 4-16
- handling cartridges, A-4
- importing cartridges through CAP, 4-11
- inspecting cartridges, A-5
- IPLing the tape library, 3-2
- locating a cartridge, 4-25
- manual, 4-22
- manually cleaning a drive, 4-16
- monitoring status information, 4-1
- moving hand-camera, 4-24
- moving robot manually, 4-23
- moving Z column, 4-25
- opening tape library front doors, 4-22
- placing tape library online, 4-35
- powering-off the tape library, 4-21
- powering-on the tape library, 3-2
- removing cartridge from hand, 4-26
- repairing leader block, A-22
- setting 9840/T9840B write-protect
 - switch, A-16, A-17
- setting DLT write-protect switch, A-15
- setting T9940 write-protect switch, A-17
- setting Ultrium write-protect switch, A-18
- storing cartridges, A-22
- operator panel
 - description of, 2-1
 - entering configuration data, 3-4
- ordering information
 - cartridge tape (DLT/SDLT), A-1
 - cartridges and labels, A-3

P

- part number
 - cartridges & labels, A-3
- port address (Fibre Channel), 3-5
- power switch
 - drive, 2-21
 - tape library, 2-18
- power-off procedure, 4-21
- power-on procedure, 3-2
- precautions
 - handling fiber-optic cables, xxii

R

- rack-mounting
 - safety, xxiii
- reach mechanism location, 4-26
- redundant power, option described, 2-20
- RISC System/6000
 - address ranges, 3-4
- robot
 - components, 1-3
 - moving manually, 4-23
- rows, 1-8

S

- safety
 - ESD prevention, xxvi
 - fiber optics, xxi
 - laser product label, xxi
 - rack-mounting, xxiii
- safety features, 1-12
- screen
 - CAP information, 2-7
 - diagnostics, 2-10
 - drive configuration, 2-14
 - drive information, 2-8
 - event log, 2-6
 - Fibre Channel interface (library), 2-13
 - library configuration, 2-12
 - library statistic, 2-6
 - library status, 2-4
 - SCSI interface (library), 2-13
- screen characteristics, setting, 3-15
- SCSI
 - configuration screen, 2-13
 - setting drive IDs, 3-10
- SDLT
 - cartridge part numbers, A-3
 - cartridge starter kit, A-2
 - cartridge, illustrated, A-5
- Seagate Ultrium
 - cartridge components, A-8
 - loading a cartridge, 4-33
 - write-protect switch, A-18
- setting
 - 9840/T9840B write-protect switch, A-16, A-17
 - DLT write-protect switch, A-15

- T9940 write-protect switch, A-17
- Ultrium write-protect switch, A-18
- software
 - fast load option, 3-7
- software, controlling, 1-12
- SPARC
 - address ranges, 3-4
- special cells, 1-10
- specifications
 - 9840/T9840B cartridges, A-20
 - colored cartridges, A-4
 - DLT cartridges, A-19
 - Ultrium cartridges, A-21
- static electricity safety, xxvi
- statistic log, 2-6
- status, 2-4
- storage capacity, tape library, 1-6
- storage cells, 1-5
- StorageTek
 - CSS telephone number, 5-1
 - Customer Resource Center (CRC), xv
 - e-Partners site, xvi
 - hardcopy publications, xvi
 - web site, xv
 - worldwide offices, 5-2
- StorageTek maintenance, 5-1
- storing cartridges, A-22
- subnet mask, 3-15
- SuperDLT. *See* SDLT
- switches
 - DLT write protect, A-15
 - power, 2-18
 - write protect, A-16, A-17

T

- T9940
 - cartridge inspection, A-7
 - cartridge label placement, A-13
 - write-protect switch, A-17
- T9940B
 - loading a cartridge, 4-31
 - unloading a cartridge, 4-32
- Taiwan warning statement, -xviii
- tape drive, configuration screen, 2-14
- tape library. *See* library
- telephone number, StorageTek CSS, 5-1
- test screen. *See* library utilities/diagnostics

screen.

U

Ultrium

cartridges

entering through CAP, 4-15

label prefixes, A-8

model/feature codes, A-9

ordering, A-9

drive types supported, 1-11

maximum number of drives, 1-6

See also specific drive type (IBM, HP, Seagate)

uninterruptable power source, described

Unix-based workstation

RISC System/6000, 3-4

SPARC, 3-4

unloading

9840/T9840B cartridge, 4-32

DLT cartridge, 4-30

T9940B cartridge, 4-32

UPS. *See* uninterruptable power source

V

VOLSER label, A-11

W

wall elements

1 CAP, 1 drive column, B-2

1 CAP, 2 drive columns, B-3

2 CAPs, 1 drive column, B-4

2 CAPs, 2 drive columns, B-5

warning

eye hazard from laser, xxi, xxii, xxiii

messages in manual, xiv

rack equipment in library, xxiii

warning statement, Taiwan, -xviii

warning, description of, xiv

web interface. *See* Horizon Library Monitor

Web password, 3-9

worldwide ID

library, 3-6

Port 0, 3-6

write protect switch, A-15, A-16, A-17

Z

Z column, moving, 4-25

Reader's Comment Form

Contact Us

Submit your questions, comments, and suggestions to StorageTek's Information Development Department. We appreciate your correspondence and are committed to responding to you.

Publication Information

Publication Name: **L700e Tape Library Operator's Guide**

Publication Part Number: **95845**

Questions and Comments:

Note: Staples can cause problems with automated mail sorting equipment. Please use pressure sensitive or other gummed tape to seal this form. If you would like a reply, please supply your name and address on the reverse side of this form.

Thank you for your cooperation. No postage stamp is required if mailed in the U.S.A.

TO COMPLY WITH POSTAL REGULATIONS, FOLD EXACTLY ON DOTTED LINES AND TAPE (DO NOT STAPLE)



NO POSTAGE
NECESSARY
IF MAILED
IN THE
UNITED STATES

BUSINESS REPLY CARD
FIRST CLASS PERMIT NO. 2 LOUISVILLE, CO U.S.A.

POSTAGE WILL BE PAID BY ADDRESSEE

INFORMATION DEVELOPMENT MS 2201
STORAGE TECHNOLOGY CORPORATION
ONE STORAGETEK DRIVE
LOUISVILLE CO 80028-2201
USA

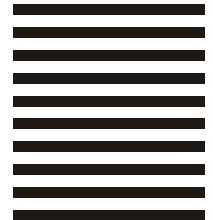

FOLD HERE AND TAPE

DO NOT STAPLE

FOLD HERE AND TAPE

If you would like a reply, please print:

Your Name: _____

Company Name: _____ Department: _____

Street Address: _____

City: _____

State: _____ Zip Code: _____

Storage Technology Corporation
One StorageTek Drive
Louisville, CO 80028-2201
USA

More information?
www.storagetek.com
1.800.786.7835

World Headquarters
Storage Technology Corporation
One StorageTek Drive
Louisville, Colorado 80028 USA
Phone: 1.800.786.7835
Fax: 719.536.4053



STORAGETEK

INFORMATION *made* POWERFUL™